

Lecture 2: The Semantics of Gender on Nouns

Yasutada Sudo
UCL
(joint work with Giorgos Spathas)

1 June 2016
Aristotle University of Thessaloniki

Slides are available at:
<http://ucl.ac.uk/~ucjtudo/gender/Lecture2.pdf>

Main Proposals

Two kinds of natural gender:

- Lexically specified gender has the gender inference in the presupposition and assertion of the lexical denotation of the noun.
- The gender inference generated via what we call **gender competition** (Percus 2011)

Some masculine-feminine pairs with natural genders (e.g. *αδερφός* (*adherfos*)-*αδερφή* (*adherfi*)) have lexically specified genders for both nouns, while others (e.g. *δάσκαλος* (*dhaskalos*)-*δασκάλα* (*dhaskala*)) only have a lexically specified gender on the feminine noun.

Natural Gender and Interpretation

Natural Gender in Greek

In Greek nouns denoting humans generally have natural gender (we'll come back to exceptions like *κορίτσι* (*koritsi*) tomorrow).

masc.	αδερφός	adherfos	'male sibling (brother)'
fem.	αδερφή	adherfi	'female sibling (sister)'

These nouns trigger gender agreement. Non-agreeing forms are ungrammatical.

- (1) Ο Πέτρος επισκέφθηκε **έναν άρρωστο αδερφό** του.
Ο Petros episkefthike **enan arosto adherfo** tu.
the.m Petros visited one.m sick.m sibling.m his
'Petros visited a brother of his.'
- (2) Ο Πέτρος επισκέφθηκε **μια άρρωστη αδερφή** του.
Ο Petros episkefthike **mia arosti adherfi** tu.
the.m Petros visited one.f sick.f sibling.f his
'Petros visited a sister of his.'

Natural Gender in Greek (cont.)

Another example:

masc.	δάσκαλος	dhaskalos	'male teacher'
fem.	δασκάλα	dhaskala	'female teacher'

- (3) Ο Πέτρος επισκέφθηκε **έναν δάσκαλο.**
Ο Petros episkefthike **enan dhaskalo.**
the.m Petros visited one.m teacher.m
'Petros visited a male teacher.'
- (4) Ο Πέτρος επισκέφθηκε **μια δασκάλα.**
Ο Petros episkefthike **mia dhaskala.**
the.m Petros visited one.f teacher.f
'Petros visited a female teacher.'

Semantics

Although superficially similar, we claim that *αδερφός* (*adherfos*) and *δάσκαλος* (*dhaskalos*) have different semantic properties.

In particular, *δάσκαλος* (*dhaskalos*) has no gender inference in the semantics.

Concretely, we analyze the nouns as follows. We assume that these nouns denote partial functions of type $\langle e, t \rangle$

- (5) a. $\llbracket \text{adherfos} \rrbracket = \lambda x_e: \text{male}(x). \text{male}(x) \wedge \text{sibling}(x)$
b. $\llbracket \text{adherfi} \rrbracket = \lambda x_e: \text{female}(x). \text{female}(x) \wedge \text{sibling}(x)$
- (6) a. $\llbracket \text{dhaskalos} \rrbracket = \lambda x_e. \text{teacher}(x)$
b. $\llbracket \text{dhaskala} \rrbracket = \lambda x_e: \text{female}(x). \text{female}(x) \wedge \text{teacher}(x)$

Epicene Nouns

Greek also has **epicene nouns**, e.g. *γιατρός* (*iatros*) 'doctor', that only have one form, but trigger masculine or feminine agreement, depending on the gender of the referent(s).

- (7) Ο Πέτρος επισκέφθηκε **έναν γιατρό**.
Ο Petros episkefthike **enan jatros**.
the.m Petros visited one.m doctor
'Petros visited a male doctor.'

- (8) Ο Πέτρος επισκέφθηκε **μια γιατρό**.
Ο Petros episkefthike **mia jatros**.
the.m Petros visited one.f doctor
'Petros visited a female doctor.'

We claim that epicene nouns have gender-neutral semantics:

- (9) $\llbracket \text{iatros} \rrbracket = \lambda x_e. \text{doctor}(x)$

More Nouns

More examples from Merchant (2014) (there might be inter-speaker variation):

Adherfos-adherfi class

kirios	'gentleman'	kiria	'lady'
antras	'man, husband'	jineka	'woman, wife'
engonos	'nephew'	egnomi	'niece'
prinkipas	'prince'	prinkipissa	'princess'
vasilias	'king'	vasilissa	'queen'

Dhaskalos-dhaskala class

manhtis	mathitria	'pupil'
pianistas	pianistria	'pianist'
tragudhistis	tragudhistria	'singer'
theos	thea	'god'
noskomos	nosokoma	'nurse'
katharistis	katharistria	'cleaner'
kathijitis	kathijitria	'professor'
fititis	fititria	'student'
thios	thia	'uncle, aunt'
nonos	nona	'godfather/godmother'

More Epicene Nouns

antipalos	'opponent'	apostoleas	'sender'
asthenis	'patient/sick person'	astinomikos	'police officer'
dhiermineas	'interpreter'	dhikastis	'judge'
dhikigoros	'lawyer'	dhimosiografos	'journalist'
epangelmatias	'professional'	epistimonas	'scientist'
filologos	'philologist'	fisikos	'physicist'
glossologos	'linguist'	goneas	'parent'
gramateas	'secretary'	idhravlikos	'plumber'
iereas	'priest/pastor'	ithopios	'actor'
ipalilos	'employee'	ipurgos	'minister'
istorikos	'historian'	jeografos	'geographer'
jeponos	'agrologist'	kalitexnis	'artist'
kinigos	'hunter'	listis	'thief'
marangos	'carpenter'	martiras	'witness'

Unmarked Gender and Gender Competition

Unmarkedness of Masculine

In Indo-European languages including Greek, masculine is semantically less marked relative to feminine and can be used as 'elsewhere gender' (see Spathas 2010 for Greek; Corbett 1991, Bobaljik & Zocca 11, Percus 2011, etc.)

We'll see that this is the case with many Greek masculine nouns.

Pronouns

Gender features on pronouns are presupposition triggers (Cooper 1983, Heim & Kratzer 1998, Heim 2008, Jacobson 2012, Spathas 2010, Sudo 2012).

Formally, presuppositions are encoded in the semantics by partializing the interpretation function $\llbracket \cdot \rrbracket$:

- (10) For any index i and assignment g ,
- $\ulcorner \text{her}_i \urcorner \in \text{dom}(\llbracket \cdot \rrbracket^g)$ iff $g(i)$ is female.
 - Whenever $\ulcorner \text{her}_i \urcorner \in \text{dom}(\llbracket \cdot \rrbracket^g)$, $\llbracket \text{her}_i \rrbracket^g = g(i)$.

Pronouns (cont.)

Unlike feminine pronouns, masculine pronouns in Greek can be used as gender-neutral pronouns.

- (11) Κάποιος φοιτητής ή κάποια φοιτήτρια έβαψε το δωμάτιο
Karios fititis i kapia fititria evapse to domatio
some.m student.m or some.f student.f painted the room

του.

tu.

his

'Some male student or some female student painted his room.'

- (12) #Κάποιος φοιτητής ή κάποια φοιτήτρια έβαψε το δωμάτιο
#Karios fititis i kapia fititria evapse to domatio
some.m student.m or some.f student.f painted the room

της.

tis.

her

'Some male student or some female student painted her room.'

In order to account for this we assume that masculine pronouns actually carry no gender inferences.

Gender Inferences of Masculine Pronouns

Masculine pronouns are of course not completely gender neutral:

- (13) Θα **τον** ψηφίσω.
Tha **ton** psifiso.
will him vote.I
'I will vote for him.'
- (14) Κάποια φοιτήτρια έβαψε το δωμάτιο **του**.
Kapia fititria evapse to domatio **tu**.
some.f student.f painted the room his
'Some female student painted his room.'

Principle of Gender Competition

In order to account for when masculine pronouns can be used for we postulate the following principle (cf. Percus 2011):

The Principle of Gender Competition

Suppose S and S' only differ in the form of some gendered item, α vs. α' . Then, the use of S in the context c is infelicitous if all of the following are true.

- ▶ α' asymmetrically entails α in the presupposition and/or assertion;
- ▶ The assertions of S and S' are equivalent; and
- ▶ S' is felicitous.

This requires the use of feminine pronouns whenever possible.

Examples

You cannot have a bound reading in (14), because the feminine pronoun *την* (*tin*) could be used instead.

- (14) Κάποια φοιτήτρια έβαψε το δωμάτιο **του**.
Kapia fititria evapse to domatio **tu**.
some.f student.f painted the room his
'Some female student painted his room.'

You can have a bound reading in (11), because the feminine pronoun could not be used.

- (11) Κάποιος φοιτητής ή κάποια φοιτήτρια έβαψε το
Kapios fititis i kapia fititria evapse to
some.m student.m or some.f student.f painted the
δωμάτιο **του**.
domatio **tu**.
room his
'Some male student or some female student painted his
room.'

Some Technical Notes

The Principle of Gender Competition is meant to apply at every 'local' level. If not, both of (15) would be ruled in:

- (15) a. #Η Μαρία έβαψε το δωμάτιο **του**
#I Maria evapse to domatio **tu**.
the.f Maria painted the room his
- b. Η Μαρία έβαψε το δωμάτιο **της**
I Maria evapse to domatio **tis**.
the.f Maria painted the room her
'Maria painted her room.'

(15a) is excluded by the Principle of Gender Competition applied at the VP-level. This could be done by dynamicizing the underlying semantics.

Determiners and Adjectives

In Greek, determiners and adjectives show gender (and number) agreement. Confining our attention to natural gender, there are two theoretical options that are compatible with our analysis of gendered nouns.

Possibility 1: Gender features on determiners and adjectives are presupposition triggers.

- (16) a. $\llbracket \text{enan} \rrbracket = \lambda P_{\langle e,t \rangle} . \lambda Q_{\langle e,t \rangle} . \exists x (P(x) \wedge Q(x))$
b. $\llbracket \text{mia} \rrbracket = \lambda P_{\langle e,t \rangle} . \lambda Q_{\langle e,t \rangle} : \forall x (P(x) \rightarrow \text{female}(x)) . \exists x (P(x) \wedge Q(x))$
- (17) a. $\llbracket \text{kalos} \rrbracket = \lambda x_e . \text{good}(x)$
b. $\llbracket \text{kali} \rrbracket = \lambda x_e : \text{female}(x) . \text{good}(x)$

Determiners and Adjectives (cont.)

Possibility 2: A semantically interpretable occurrence of the gender feature outside of DP, which syntactically agrees with the uninterpretable occurrences appearing on determiners and adjectives (Sauerland 2003, 2008).

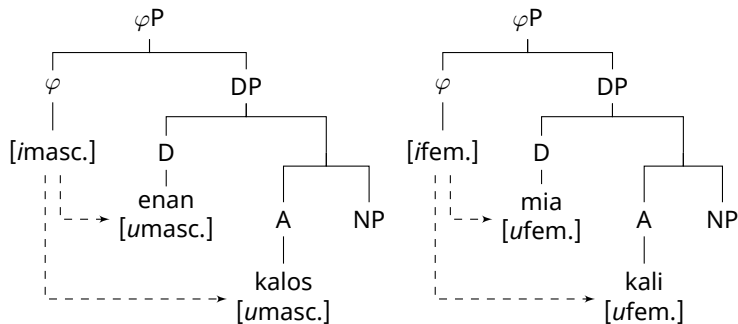

- (18) a. $\llbracket [imasc.] \rrbracket = \lambda x_e. x$
b. $\llbracket [ifem.] \rrbracket = \lambda x_e: \text{female}(x). x$

Nouns with Natural Genders

Noun Denotations Again

Our main claim is that natural gender features on nouns are interpreted differently from gender features on determiners and adjectives. Specifically:

- (5) a. $\llbracket \text{adherfos} \rrbracket = \lambda x_e. \text{male}(x). \text{male}(x) \wedge \text{sibling}(x)$
b. $\llbracket \text{adherfi} \rrbracket = \lambda x_e. \text{female}(x). \text{female}(x) \wedge \text{sibling}(x)$
- (6) a. $\llbracket \text{dhaskalos} \rrbracket = \lambda x_e. \text{teacher}(x)$
b. $\llbracket \text{dhaskala} \rrbracket = \lambda x_e. \text{female}(x). \text{female}(x) \wedge \text{teacher}(x)$
- (9) $\llbracket \text{jatros} \rrbracket = \lambda x_e. \text{doctor}(x)$

Evidence

1. Plural nouns
2. Negative existentials
3. Focus constructions

Plurals

The plural morpheme is standardly analyzed as a distributive operator, which is a kind of universal quantifier (cf. Link 1983, Winter 2001).

- (19) a. $\llbracket \text{dog} \rrbracket = \{ x_e \mid x \text{ is a dog} \}$
b. $\llbracket \text{dogs} \rrbracket = \left\{ x_e \mid \begin{array}{l} x \text{ has one or more atomic parts} \\ \text{and every atomic part of } x \text{ is a dog} \end{array} \right\}$

(20) $\llbracket -s \rrbracket = \lambda P_{\langle e,t \rangle} . \lambda x_e . |x| > 0 \wedge \forall y_e [y \sqsubseteq_a x \rightarrow P(y)]$

If a plural noun is formed from a noun with a lexically specified gender, it can only describe groups every member of which has the gender.

Plural Gendered Nouns

- (21) a. #Ο Πέτρος και η Μαρία είναι **αδερφοί** του Ιωάννη.
#Ο Petros ke i Maria ine **adherfi** tu Jani.
the Petros and the Maria are sibling.m.pl the.gen Janis.gen
'*Petros and Maria are brothers of Janis's.'
- b. #Ο Πέτρος και η Μαρία είναι **αδερφές** του Ιωάννη.
#Ο Petros ke i Maria ine **adherfes** tu Jani.
the Maria and the Petros are sibling.f.pl the.gen Janis.gen
'Maria and Petros are sisters of Janis's.'
- (22) a. Ο Πέτρος και η Μαρία είναι **δάσκαλοι** στην Κατερίνη.
Ο Petros ke i Maria ine **dhaskali** stin Katerini.
the Petros and the Maria are teachers.m in.the Katerini
'Petros and Maria are teachers in Katerini.'
- b. #Ο Πέτρος και η Μαρία είναι **δασκάλες** στην Κατερίνη.
#Ο Petros ke i Maria ine **dhaskales** stin Katerini.
the Petros and the Maria are teachers.f in.the Katerini

'Doctors'

- (23) a. Ο Πέτρος και η Μαρία είναι **καλοί γιατροί**.
Ο Petros ke i Maria ine **kali jatri**.
the Petros and the Maria are good.m doctors
'Petros and Maria are good doctors.'
- b. #Ο Πέτρος και η Μαρία είναι **καλές γιατροί**.
#Ο Petros ke i Maria ine **kales jatri**.
the Petros and the Maria are good.f doctors

Plural Gendered Nouns and Competition

The infelicity of (24) is predicted by the Principle of Gender Competition, because the feminine plural nouns could be used instead.

- (24) a. #Η Έλενα και η Μαρία είναι **δάσκαλοι** στην
#I Elena ke i Maria ine **dhaskali** stin
the Elena and the Maria are teachers.m in.the
Κατερίνη.
Katerini.
Katerini
'Elena and Maria are teachers in Katerini.'
- b. #Η Έλενα και η Μαρία είναι καλοί **γιατροί**.
#I Elena ke i Maria ine kali **jatri**.
the Elena and the Maria are good.m doctors
'Elena and Maria are good doctors.'

Negative existential sentences

In Negative existential sentences nouns with lexically specified genders restrict the domain of quantification. Since they are in downward entailing contexts, furthermore, this means that they will give rise to weaker entailments.

- (25) a. Ο Πέτρος δεν έχει κανέναν **αδερφό**.
Ο Petros dhen exi kanenan **adherfo**.
the Petros not has no.m sibling.m
'Petros has no brother.' ⇒ Petros has no sister
- b. Ο Πέτρος δεν έχει καμιά **αδερφή**.
Ο Petros dhen exi kamia **adherfi**.
the Petros not has no.f sibling.f
'Petros has no sister.' ⇒ Petros has no brother

Negative existential sentences (cont.)

- (26) a. Ο Πέτρος δεν έχει κανέναν **δάσκαλο** στην
Ο Petros dhen exi kanenan **dhaskalo** stin
the Petros not has no.m teacher.m in.the
Κατερίνη.
Katerini.
Katerini
'Petros has no teacher in Katerini.'
⇒ Petros has no female teacher in Katerini
- b. Ο Πέτρος δεν έχει καμιά **δασκάλα** στην Κατερίνη.
Ο Petros dhen exi kamia **dhaskala** stin Katerini.
the Petros not has no.f teacher.f in.the Katerini
'Petros has no female teacher in Katerini.'
⇒ Petros has no male teacher in Katerini

'No Doctor'

- (27) a. Ο Πέτρος δεν έχει κανέναν **γιατρό**.
Ο Petros dhen exi kanenan **jatro**.
the Petros not has no.m doctor
'Petros has no doctor.' ⇒ Petros has no female doctor
- b. Ο Πέτρος δεν έχει καμιά **γιατρό**.
Ο Petros dhen exi kamia **jatro**.
the Petros not has no.f doctor
'Petros has no female doctor.'
⇒ Petros has no male doctor

φ -Features in Focus Constructions

Focus constructions semantically involve reference to alternatives.

Focus alternatives generally are oblivious to presuppositions triggered by φ -features (' φ -presuppositions'), including gender features (see Spathas 2010, Jacobson 2012, Sauerland 2013).

- (28) a. Of all the students, only I did my homework.
 $\Rightarrow \neg(\text{Mary did her homework})$
 $\Rightarrow \neg(\text{John did his homework})$
- b. Of all the students, only John did his homework.
 $\Rightarrow \neg(\text{John did his homework})$
 $\Rightarrow \neg(\text{I did my homework})$
- c. Of all the students, only Mary did her homework.
 $\Rightarrow \neg(\text{Mary did her homework})$
 $\Rightarrow \neg(\text{I did my homework})$

φ -Features in Focus Constructions (cont.)

Assertions are never ignored.

- (29) Of all the students, only Mary is a female athlete.
 $\Rightarrow \neg(\text{John is a male athlete})$

This can be used as a test for the presence of gender inferences in the assertion.

Gendered Nouns in Focus Constructions

- (30) a. Μόνο ο Πέτρος είναι **αδερφός** του Ιωάννη.
Mono o Petros ine **adherfos** tu Jani.
only the Petros is sibling.m the.gen Janis.gen
'Only Petros is a brother of Janis'.
⇒ Maria is not Janis's sister.
- b. Μόνο η Μαρία είναι **αδερφή** του Ιωάννη.
Mono i Maria ine **adherfi** tu Jani.
only the Maria is sibling.f the.gen Janis.gen
'Only Maria is a sister of Janis'.
⇒ Petros is not Janis's brother.

Both of these nouns assert the gender.

Gendered Nouns in Focus Constructions (cont.)

- (31) a. Μόνο ο Πέτρος είναι **δάσκαλος**.
Mono o Petros ine **dhaskalos**.
only the Petros is teacher.m
'Only Petros is a teacher.' ⇒ Maria is not a teacher.
- b. Μόνο η Μαρία είναι **δασκάλα**.
Mono i Maria ine **dhaskala**.
only the Maria is teacher.f
'Only Maria is a teacher.' ⇒ Petros is not a teacher.

δάσκαλος (dhaskalos) does not assert the gender!

'Doctors' in Focus Constructions

- (32) a. Μόνο ο Πέτρος είναι **καλός γιατρός**.
Mono o Petros ine **kalos jatros**.
only the Petros is good.m doctor
'Only Petros is a good doctor.' ⇒ Maria is not a good doctor.
- b. Μόνο η Μαρία είναι **καλή γιατρός**.
Mono i Maria ine **kali jatros**.
only the Maria is good.f doctor
'Only Maria is a good doctor.' ⇒ Petros is not a good doctor.

Superlatives

Other focus constructions point to the same conclusions, including superlatives, ordinals and nominal *only*.

- (33) a. Ο Πέτρος είναι ο καλύτερος **αδερφός** Ιωάννη.
Ο Petros ine ο kaliteros **adherfos** Jani.
the Petros is the.m best.m sibling.m Janis.gen
'Petros is the best brother of Janis' (among Janis' brothers).'
- b. Η Μαρία είναι η καλύτερη **αδερφή** Ιωάννη.
I Maria ine i kaliteri **adherfi** Jani.
the Maria is the.f best.f sibling.f Janis.gen
'Maria is the best sister of Janis' (among Janis' sisters).'

Superlatives (cont.)

- (34) a. Ο Πέτρος είναι ο καλύτερος **δάσκαλος**.
Ο Petros ine o kaliteros **dhaskalos**.
the Petros is the.m best.m teacher.m
'Petros is the best teacher (among the male and female teachers).'
- b. Η Μαρία είναι η καλύτερη **δασκάλα**.
Η Maria ine i kaliteri **dhaskala**.
the Maria is the.f best.f teacher.f
'Maria is the best teacher (among the female teachers).'

'Best Doctor'

- (35) a. Ο Πέτρος είναι ο καλύτερος **γιατρός**.
Ο Petros ine o kaliteros **iatros**.
the Petros is the.m best.m doctor

'Petros is the best doctor (among the male and female doctors).'

- b. Η Μαρία είναι η καλύτερη **γιατρός**.
Η Maria ine i kaliteri **iatros**.
the Maria is the.f best.f doctor

'Maria is the best doctor (among the male and female doctors).'

Summary

- (5) a. $\llbracket \text{adherfos} \rrbracket = \lambda x_e: \text{male}(x). \text{male}(x) \wedge \text{sibling}(x)$
b. $\llbracket \text{adherfi} \rrbracket = \lambda x_e: \text{female}(x). \text{female}(x) \wedge \text{sibling}(x)$
- (6) a. $\llbracket \text{dhaskalos} \rrbracket = \lambda x_e. \text{teacher}(x)$
b. $\llbracket \text{dhaskala} \rrbracket = \lambda x_e: \text{female}(x). \text{female}(x) \wedge \text{teacher}(x)$
- (9) $\llbracket \text{jatros} \rrbracket = \lambda x_e. \text{doctor}(x)$

Gender features on human-denoting nouns are interpreted differently from gender features on determiners and adjectives in that the gender inference is also present in the assertion (contrary to Sauerland 2008, Bobaljik & Zocca 2011, Merchant 2014).

Two kinds of masculine nouns (contrary to Percus 2011):

- *αδερφός* (*adherfos*) has lexically specified gender.
- *δάσκαλος* (*dhaskalos*) has no lexically specified gender.

Summary (cont.)

The Principle of Gender Competition correctly regulates the uses of semantically gender-neutral nouns.

- (36) a. #Η Μαρία είναι **καλός γιατρός**.
#I Maria ine kalos **iatros**.
the Maria is good.m doctor
- b. #Η Μαρία είναι **δάσκαλος**.
#I Maria ine **dhaskalos**.
the Maria is teacher.m

Although these examples are semantically coherent, they are made unacceptable due to the felicity of their feminine alternatives.

Appendix

For masculine nouns like *αδερός* (*adherfos*) ‘male sibling’, the observations are actually consistent with the possibility that their gender presupposition is also semantically null.

However, the infelicity of sentences like (37) suggest that this is not the case.

- (37) #I Maria ine **adherfos** tu Jani.
 the Maria is sibling.m the.gen Janis.gen
 ‘Maria is a brother of Janis’s.’

Also, by keeping the masculine presupposition in the denotation of *adherfos*, we can maintain the uniformity of the interpretation of gender features on nouns: if a noun is lexically specified for natural gender, it both presupposes and asserts it, and if not, it is simply unmarked.

References

- ▶ Bobaljik & Zocca (2011) Gender markedness: the anatomy of a counter-example. *Morphology*, 21.
- ▶ Cooper (1983) *Quantification and Semantic Theory*.
- ▶ Corbett (1991) *Gender*.
- ▶ Heim (2008) Features on bound pronouns. In *Phi Theory: Phi-Features Across Modules and Interfaces*.
- ▶ Heim & Kratzer (1998) *Semantics in Generative Grammar*.
- ▶ Jacobson (2012) The direct compositionality and 'uninterpretability': The case of (sometimes) 'uninterpretable' features on pronouns. *Journal of Semantics*, 29.
- ▶ Kramer (2015) *The Morphosyntax of Gender*.
- ▶ Link (1983) The logical analysis of plurals and mass terms: A lattice theoretical approach. *Meaning, Use, and the Interpretation of Language*.
- ▶ Merchant (2014) Gender mismatches under nominal ellipsis. *Lingua*, 151.

References

- ▶ Percus (2011) Gender features and interpretation: a case study. *Morphology*, 21.
- ▶ Sauerland (2003) A new semantics for number. *SALT 13*.
- ▶ Sauerland (2008) On the semantics markedness of phi-features. *Phi Theory: Phi-Features Across Modules and Interfaces*.
- ▶ Spathas (2010) *Focus on Anaphora*. Ph.D. dissertation, Utrecht.
- ▶ Sudo (2012) *On the Semantics of Phi Features on Pronouns*. Ph.D. dissertation, MIT.
- ▶ Winter (2001) *Flexibility Principles in Boolean Semantics*.