

# Can Imaging of Nanoparticles extend to Single Molecules?

Ian Robinson

Ross Harder

Steven Leake

Marcus Newton

Moyu Watari

Loren Beitra

London Centre for Nanotechnology  
Diamond Light Source

Institute for Molecules and Materials  
Radboud University  
May 2009

# Outline

- Coherent x-ray diffraction imaging
- Sensitivity to internal strain
- Nanocrystals and nanowires
- Biosensors
- Single molecule imaging
- Planning for initial LCLS experiments

# Diamond Light Source (RAL)

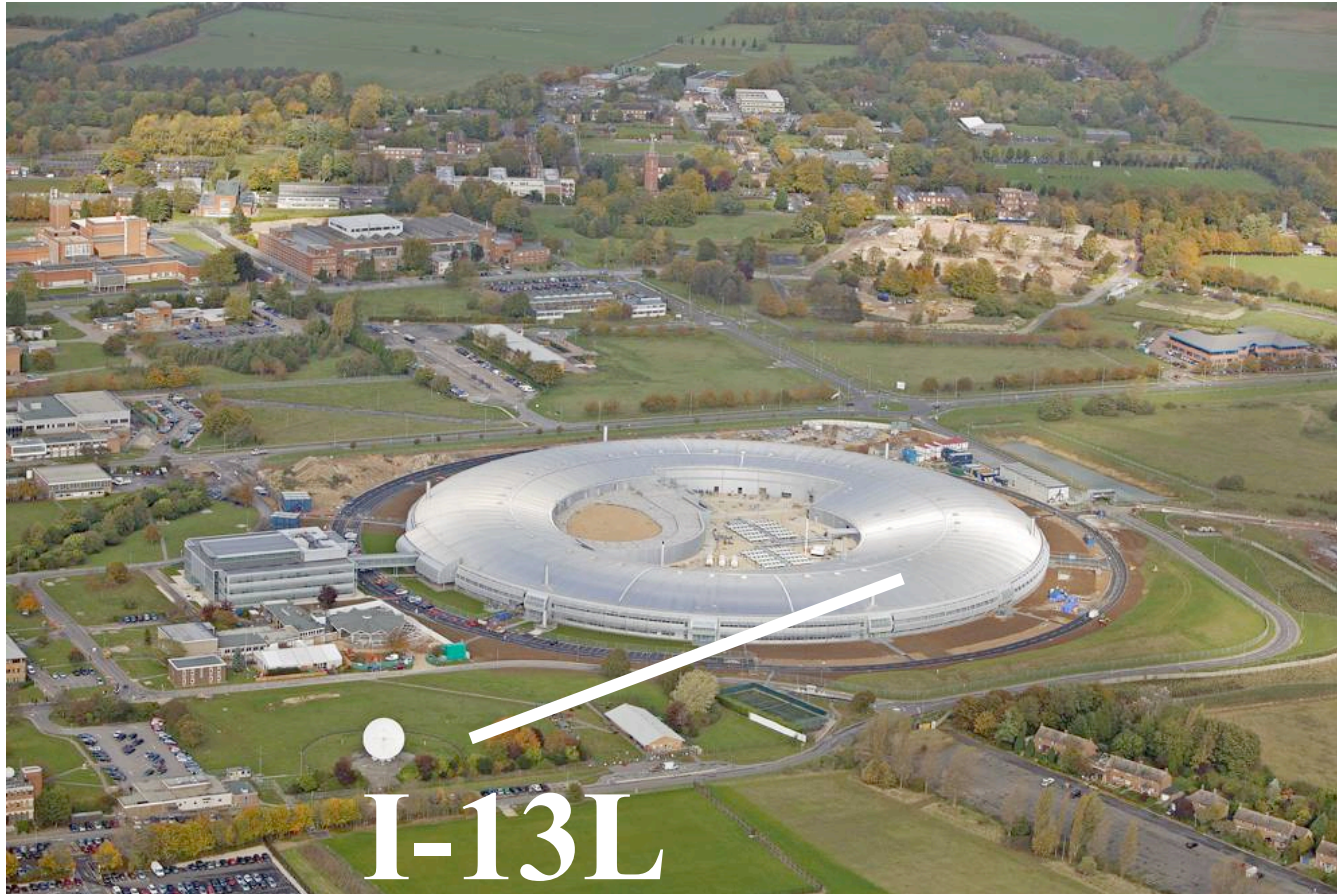

I-13L

I. K. Robinson, Bremen 2009

# Diamond in-vacuum X-ray Undulator

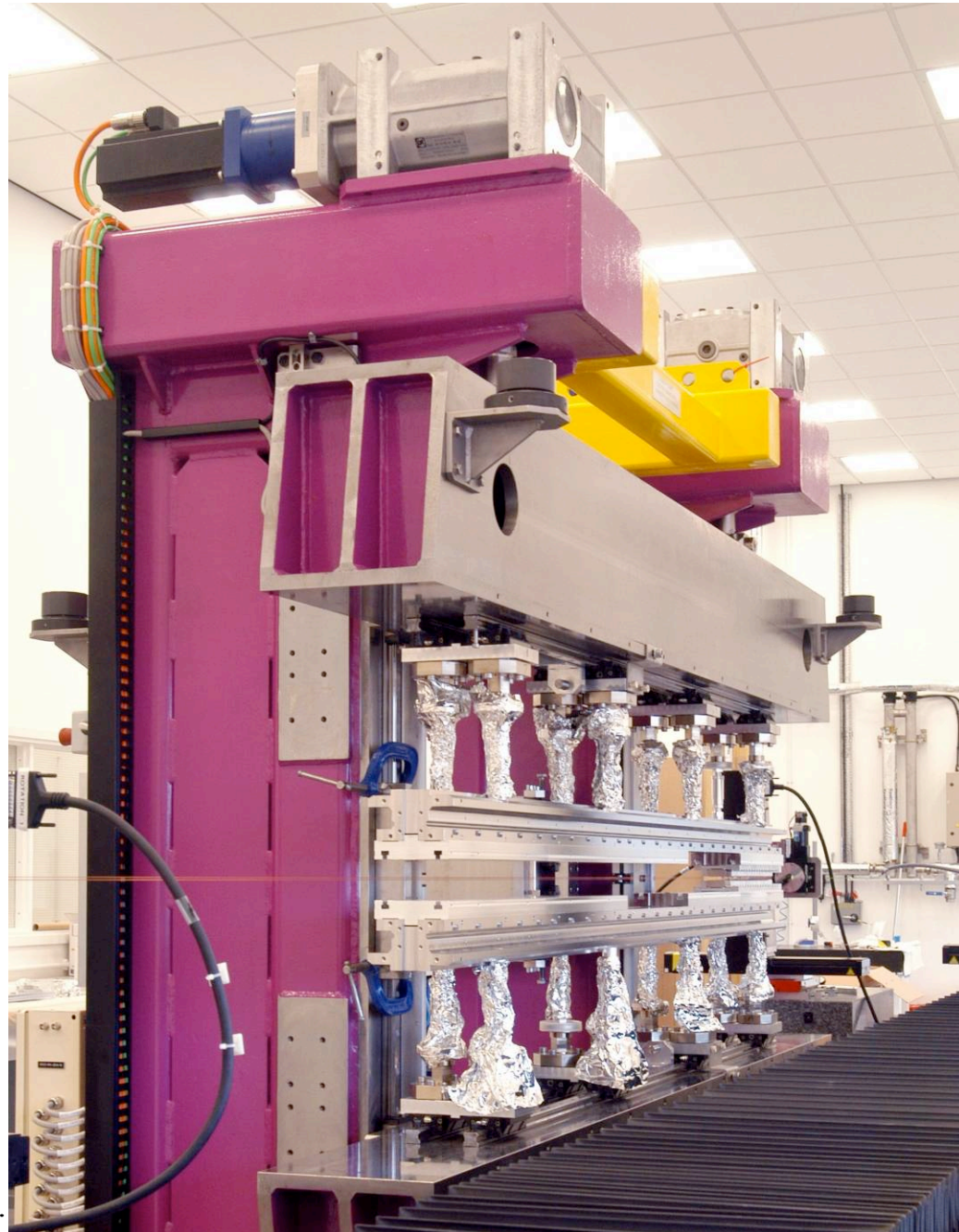



# Coherent X-ray Diffraction Imaging

APS  $\xi_{\text{HOR}} = 20\mu\text{m}$ , focus to  $1\mu\text{m}$

LCLS  $\xi_{\text{HOR}} > 500\mu\text{m}$ , focus to  $0.1\mu\text{m}$

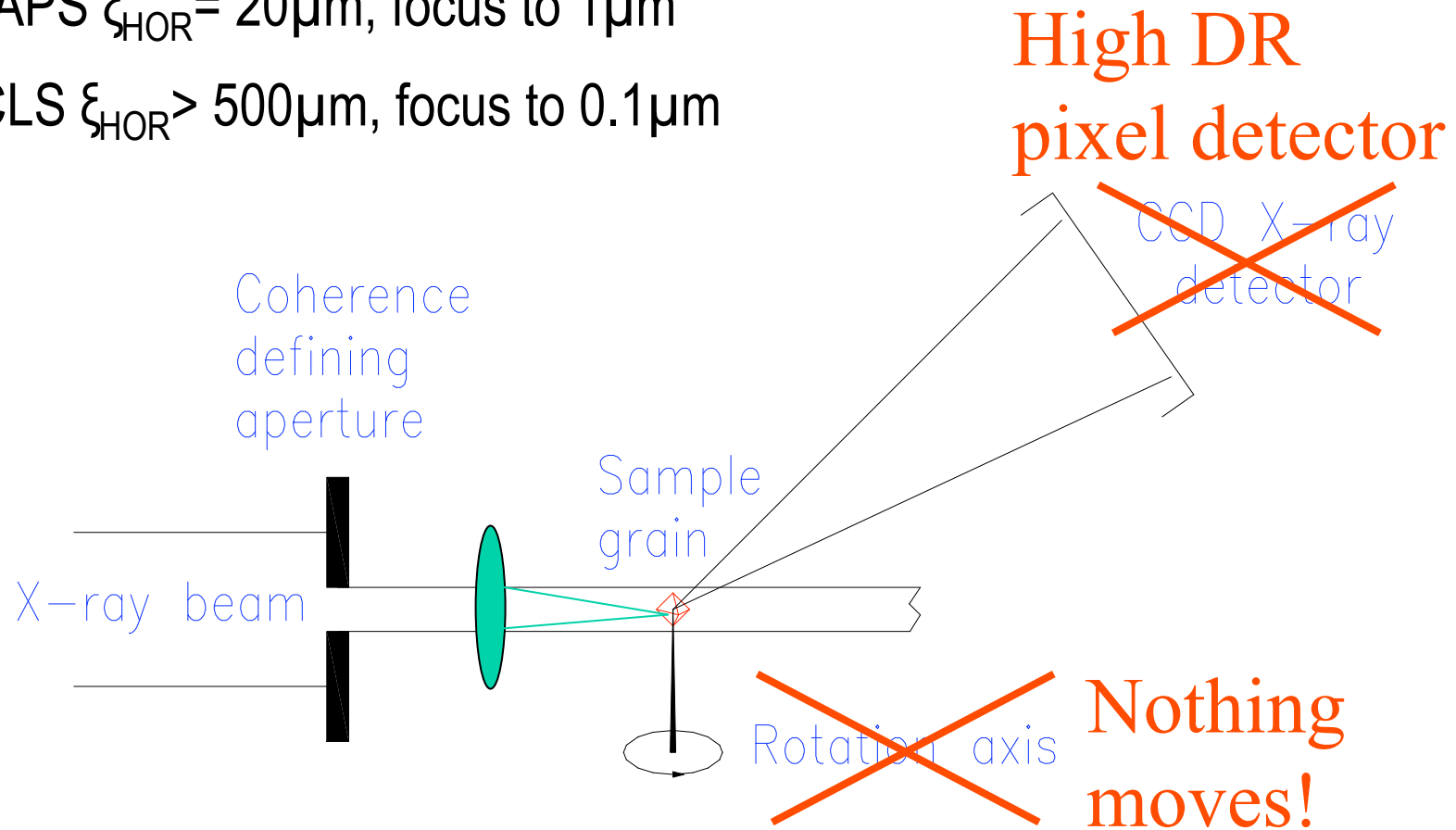

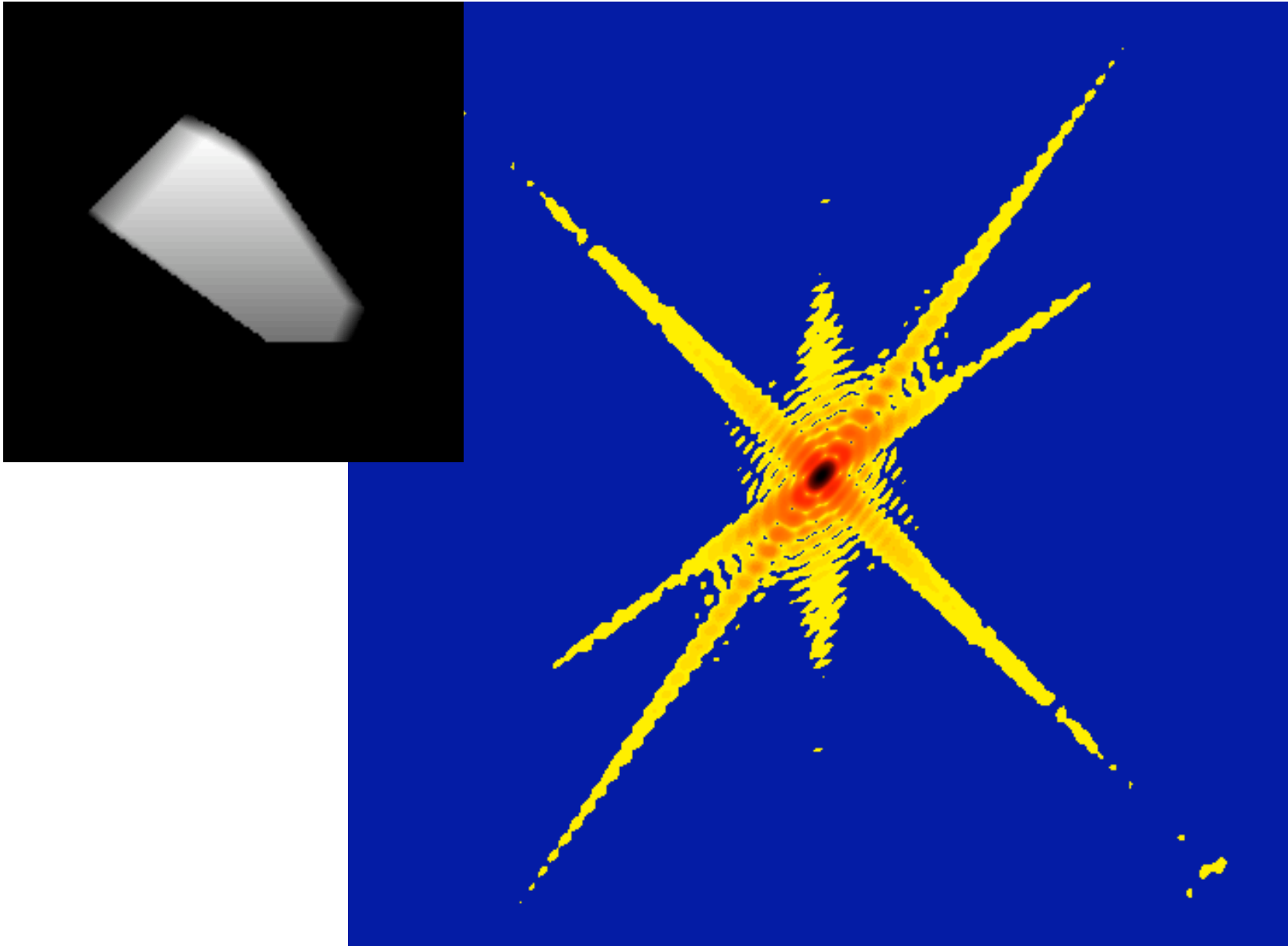

# Chemically Synthesized Silver Nanocubes

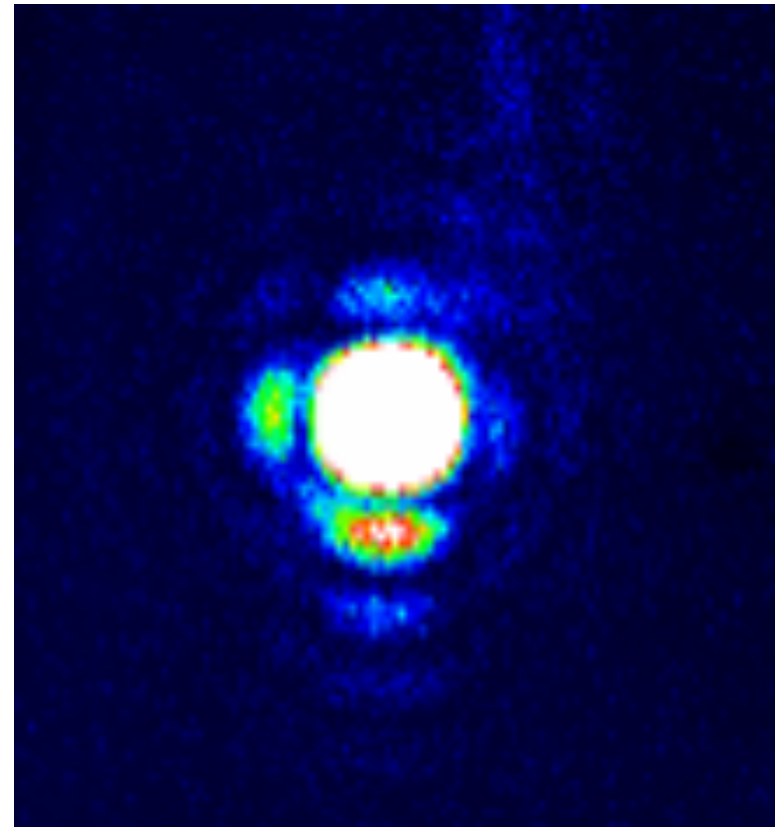
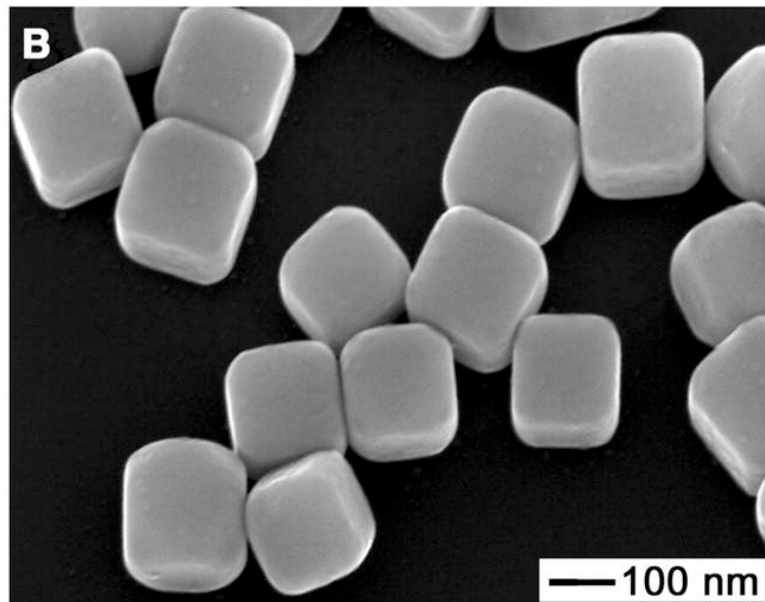

Yugang Sun and Younan Xia,  
*Science* 298 2177 (2003)

Rocking  
scan of Ag  
cubes with  
 $0.01^\circ$  steps

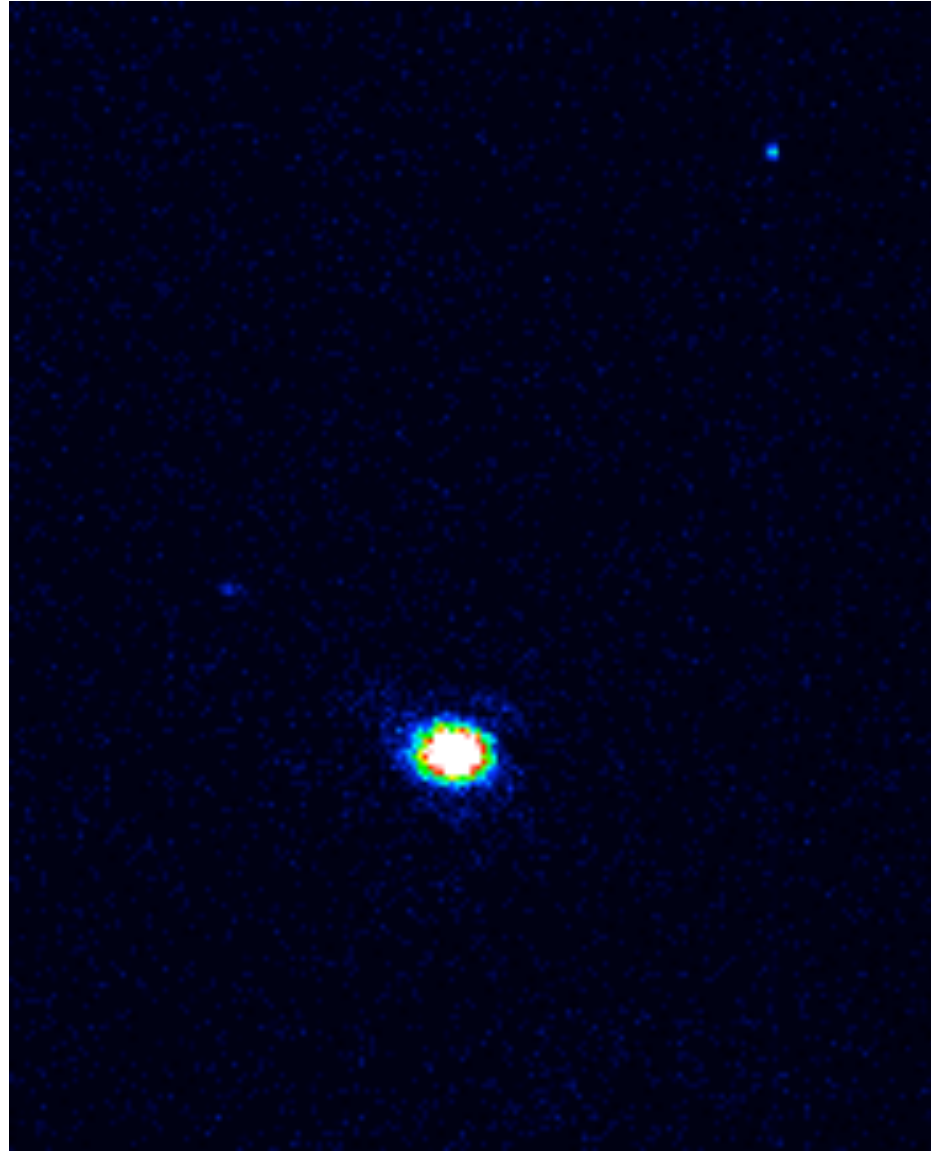

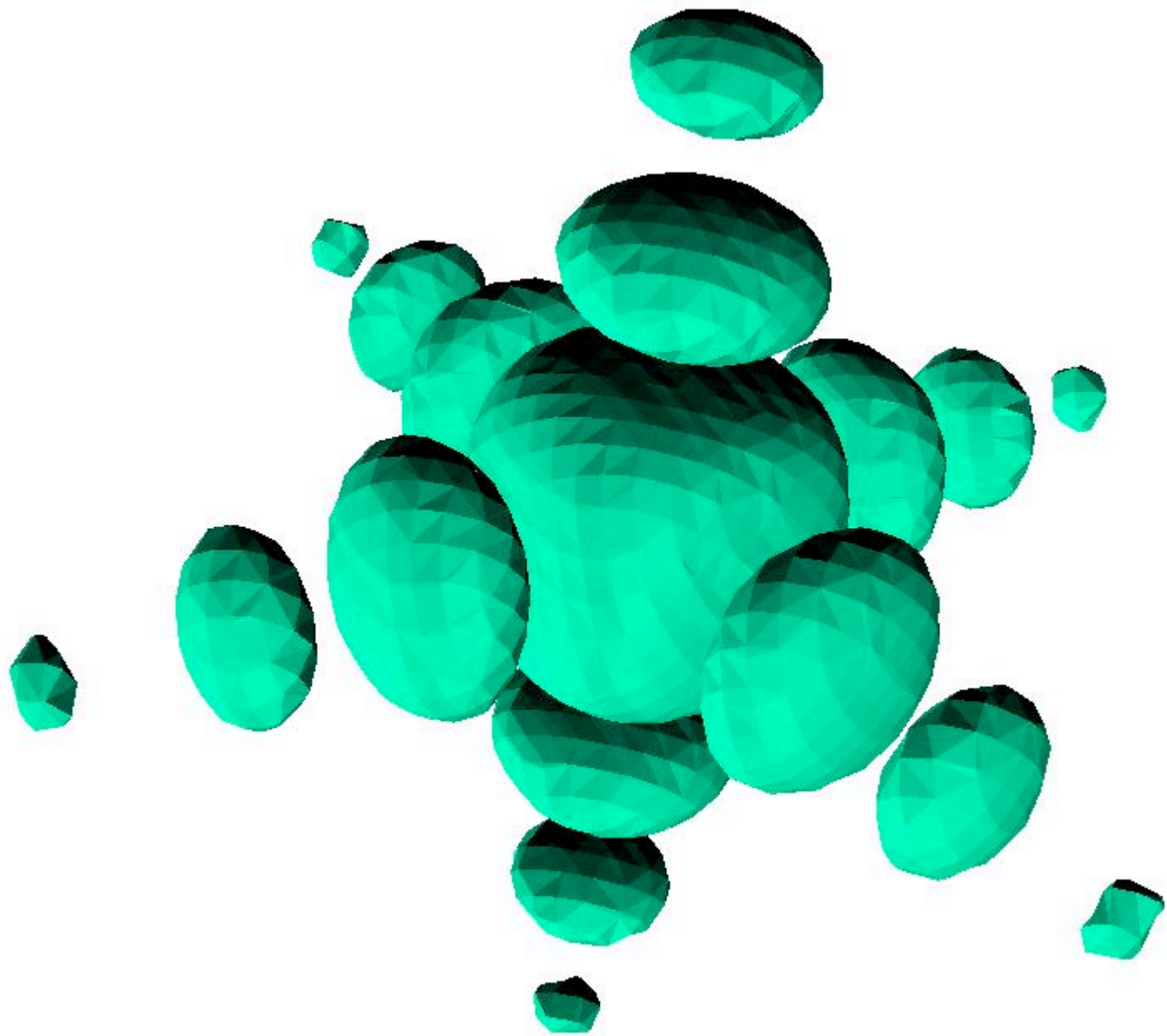

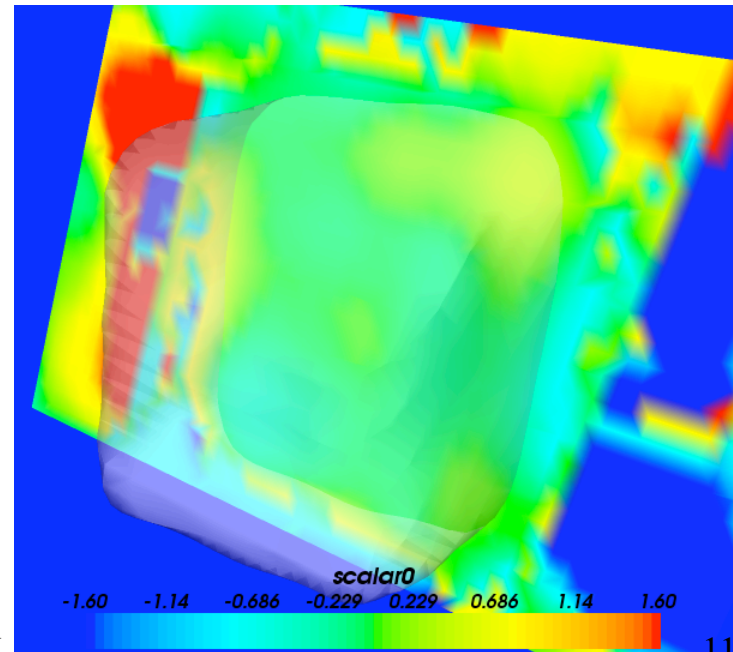
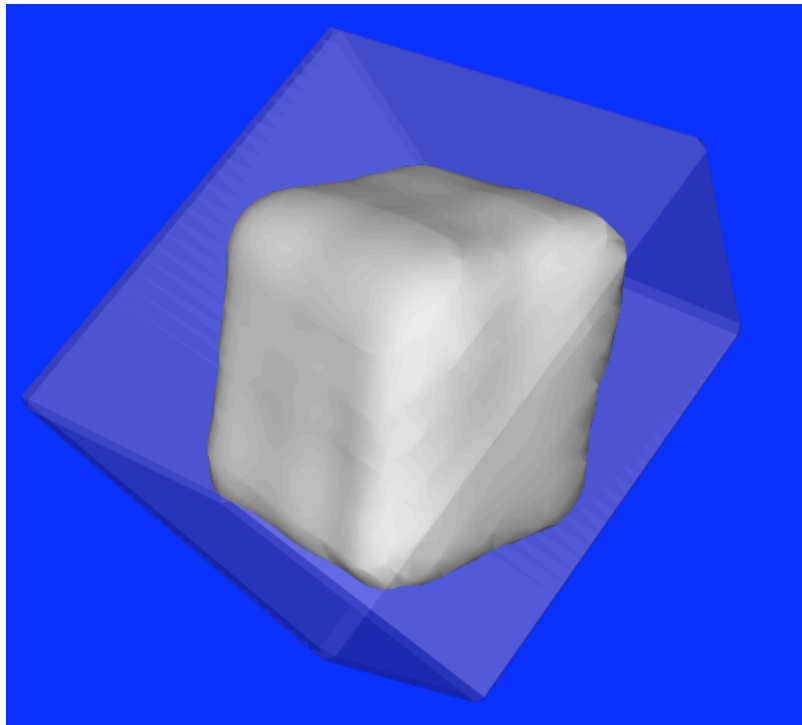
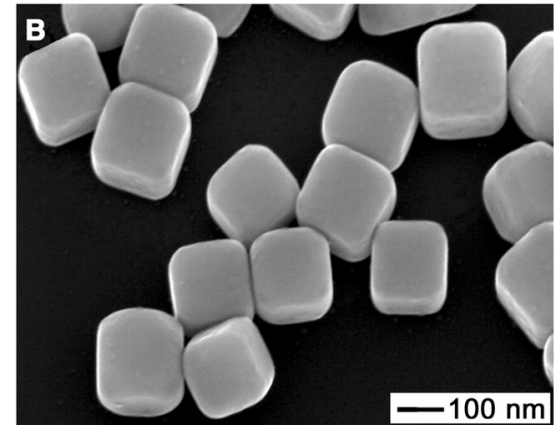
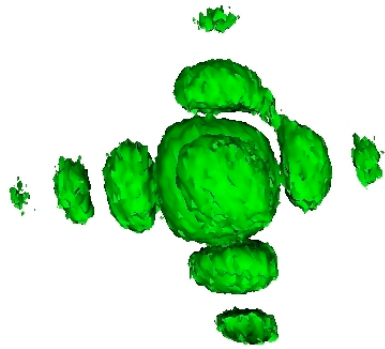
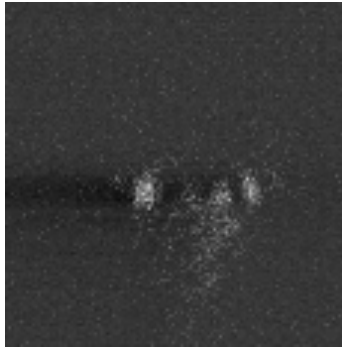

# Generic “Error Reduction” method

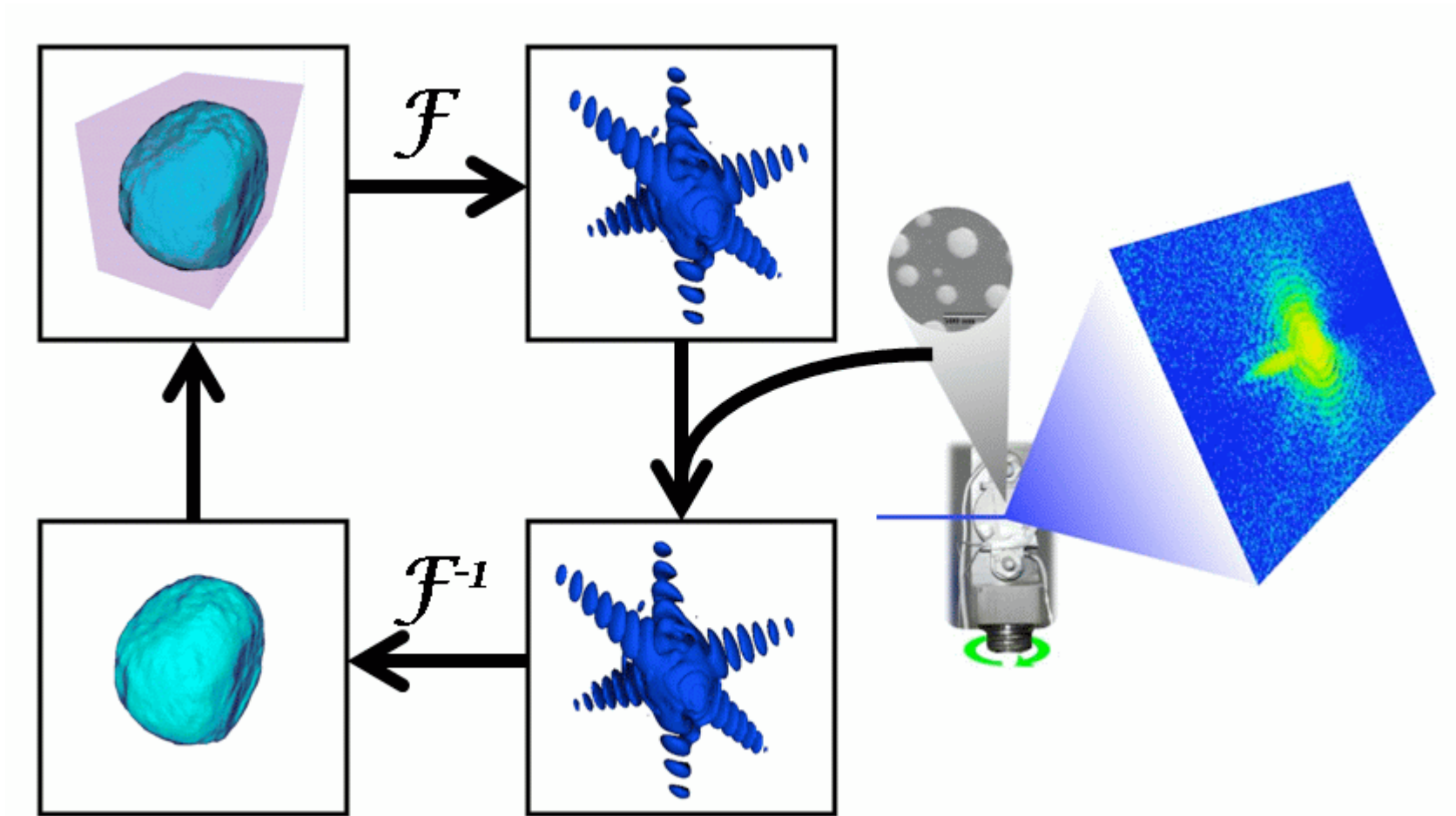

J. R. Fienup *Appl. Opt.* 21 2758 (1982)

R. W. Gerchberg and W. O. Saxton *Optik* 35 237 (1972)

I. K. Robinson, Bremen 2009

# Gold nanocrystal reconstruction

showing support used for 20 HIO followed by 10 ER

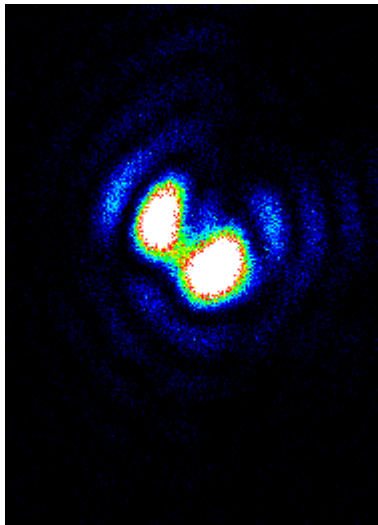

# Coherent Diffraction from Crystals

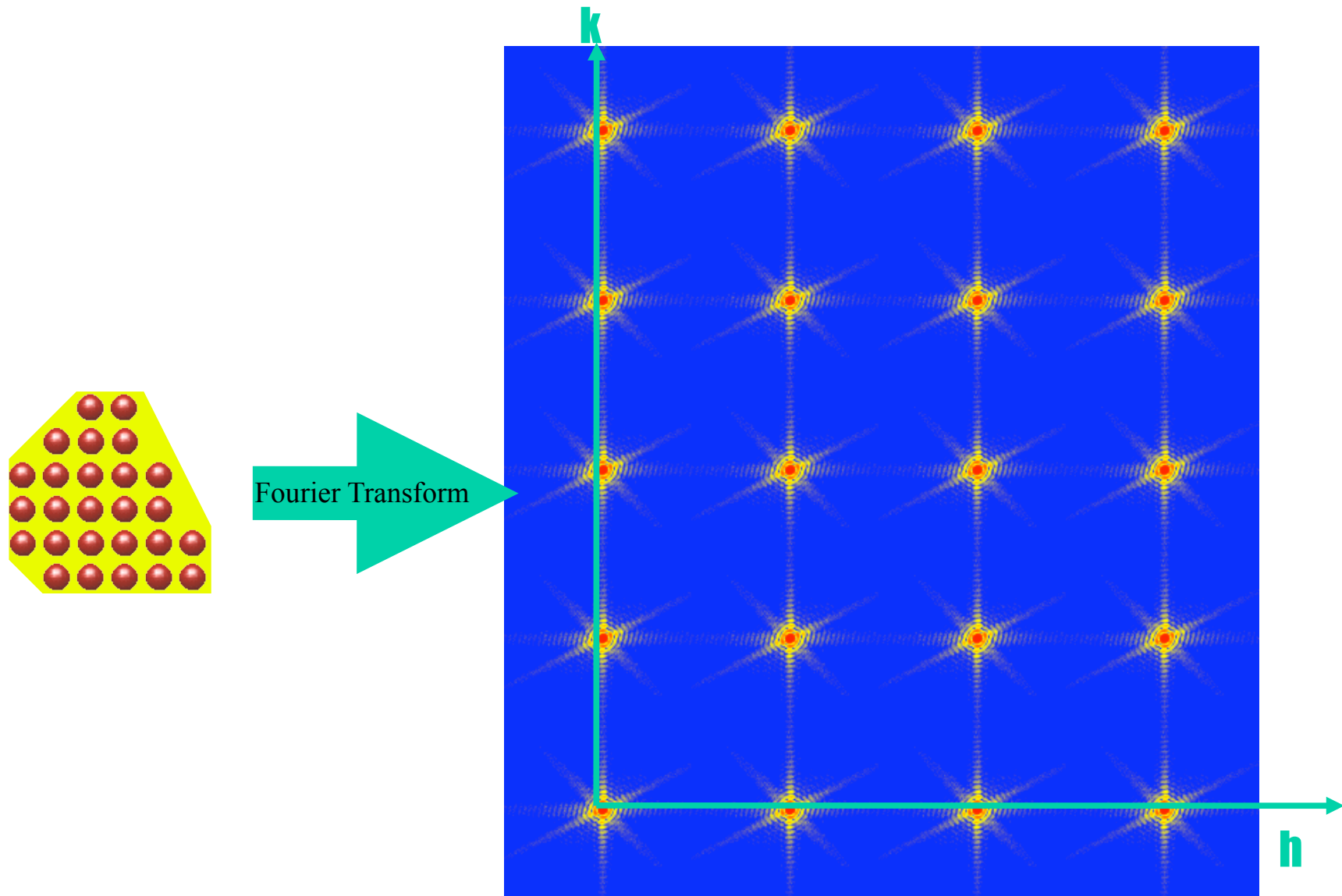

# Contact strain of Zeolite ZSM-5

with Hyunjung Kim and K. B. Yoon at Sogang University

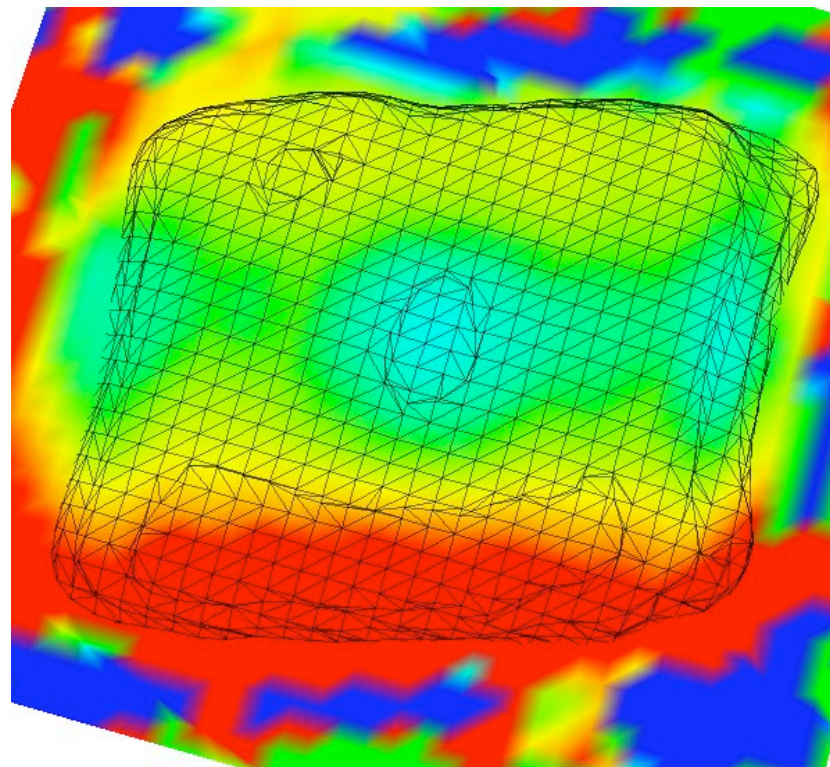
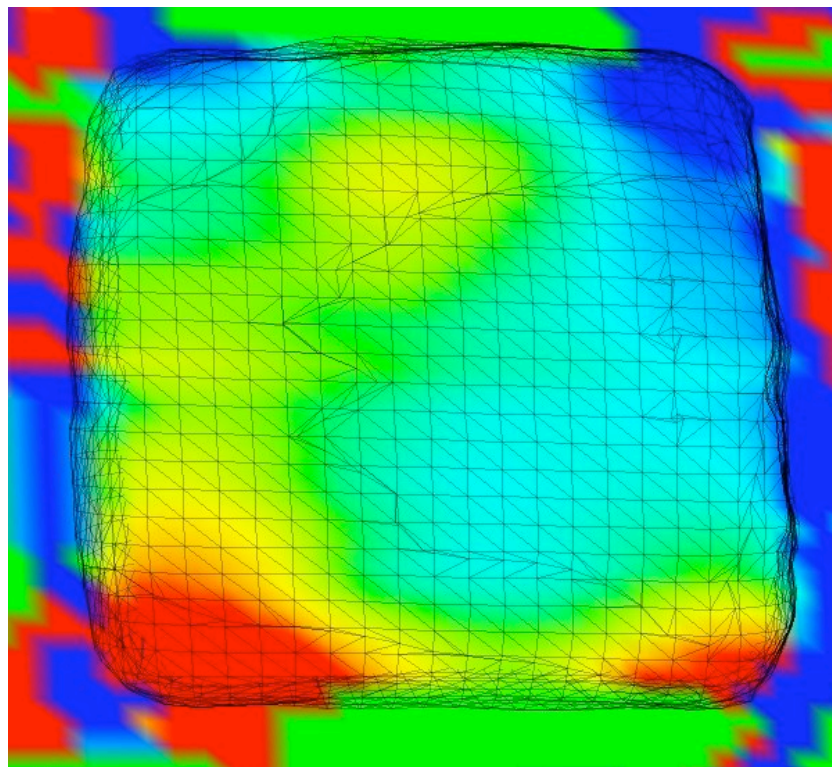

# VLS growth of nanowires

S. Kodambaka et al., *Science* 316 729 (2007)

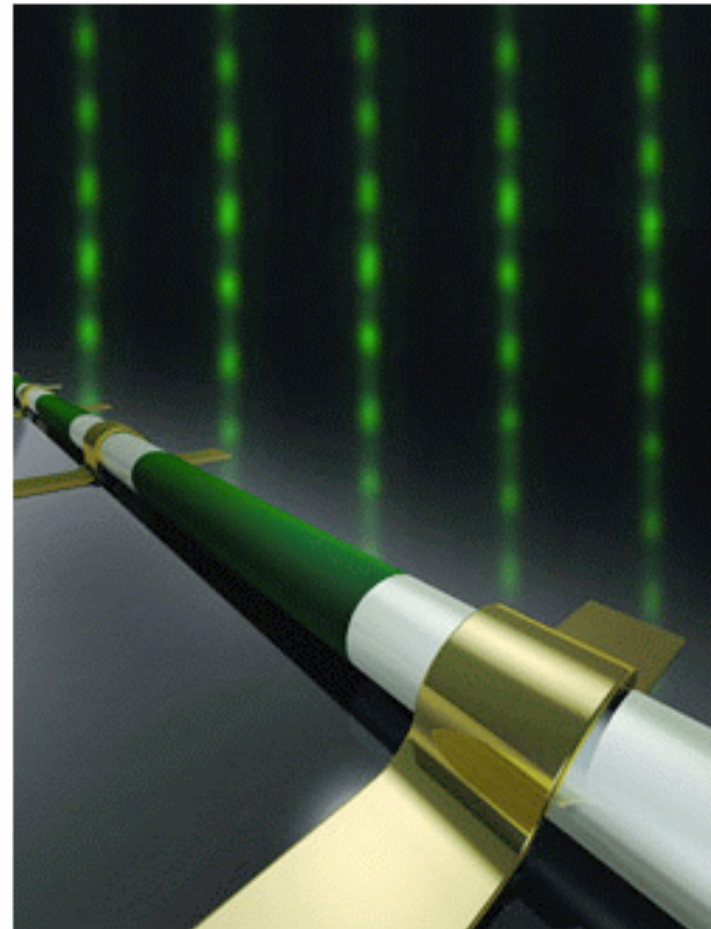
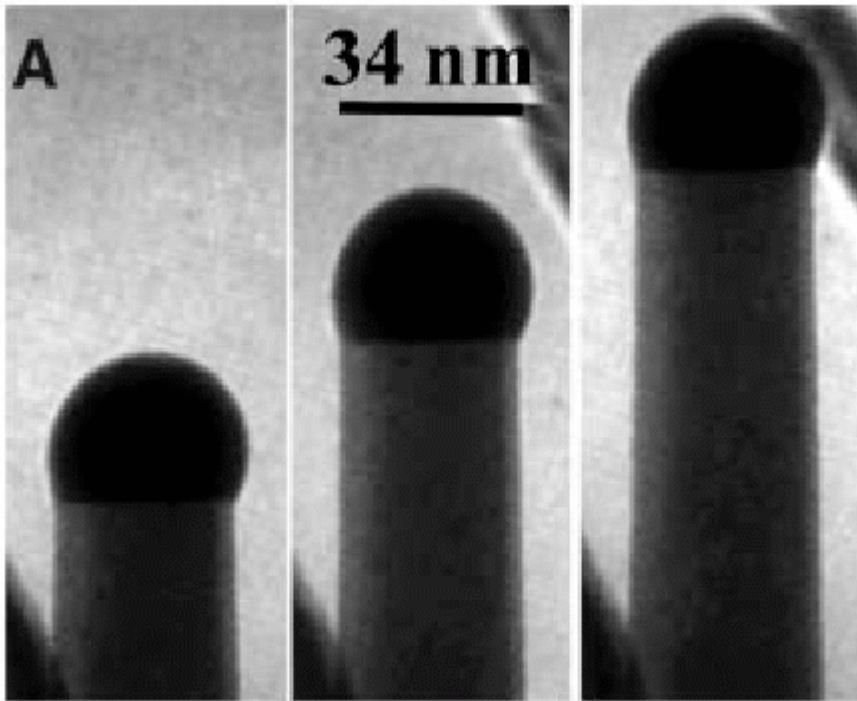

I. K. Robinson, IMM, N  
NiSi/Si nanowire heterostructure  
devices. *Nature* **430**, 61 (2004).

# Reconstruction of InP nanowire

CVD on Si, Suneel Kodambaka, UCLA

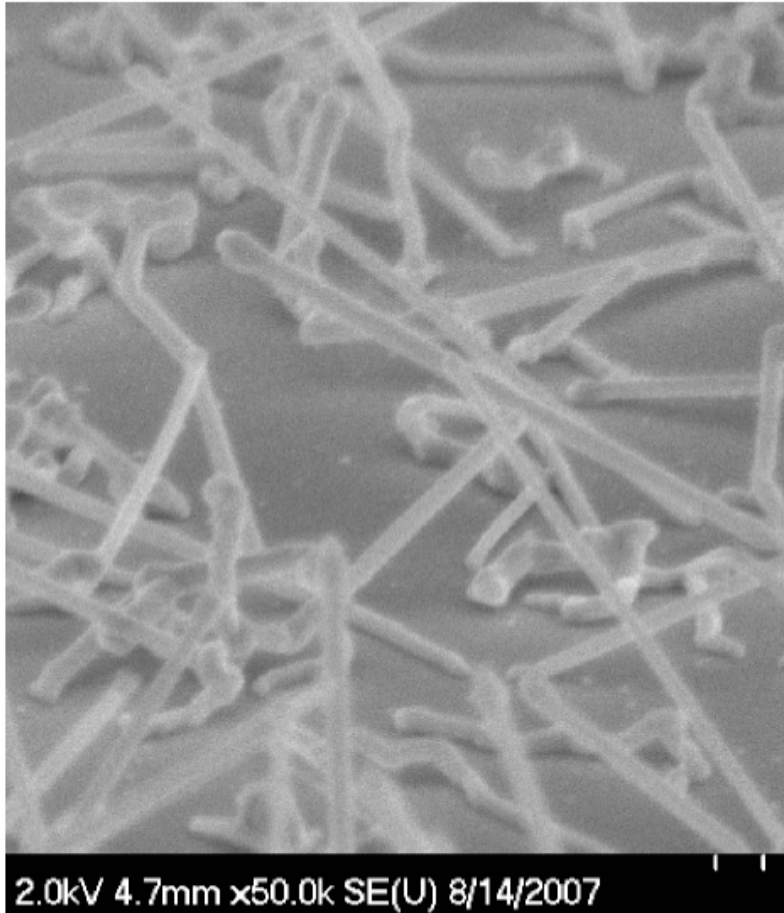

InP nanowires grown on Si (111)

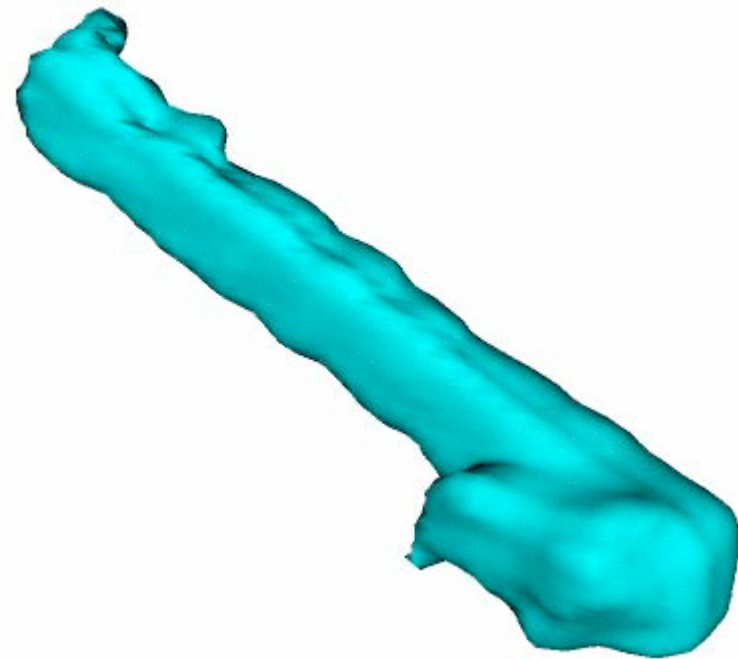

# Phase structure in nanowires

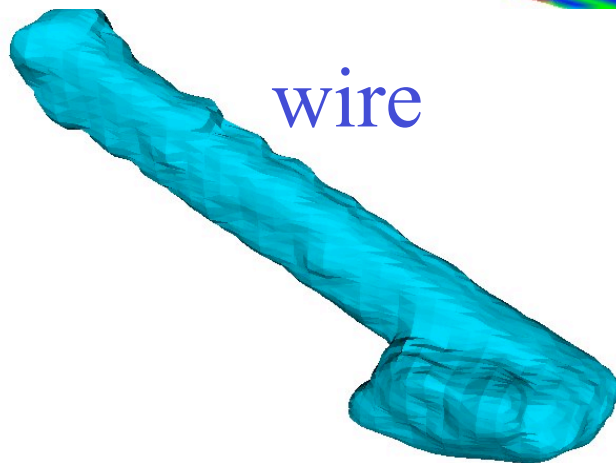
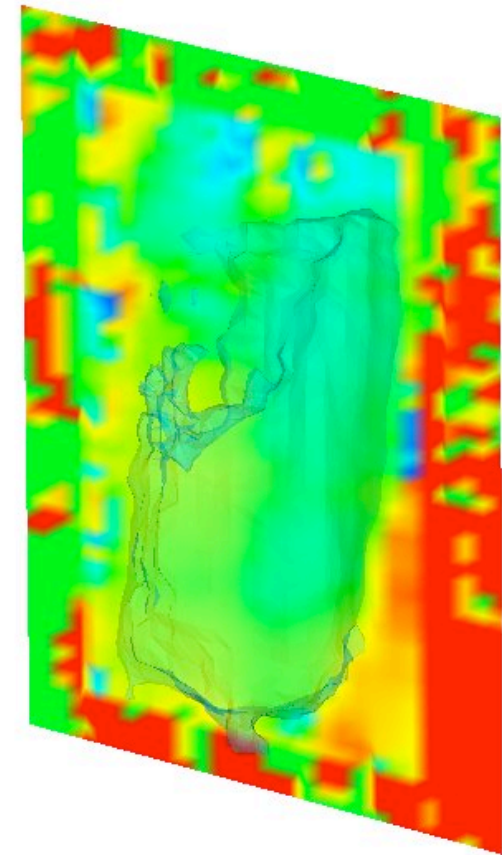
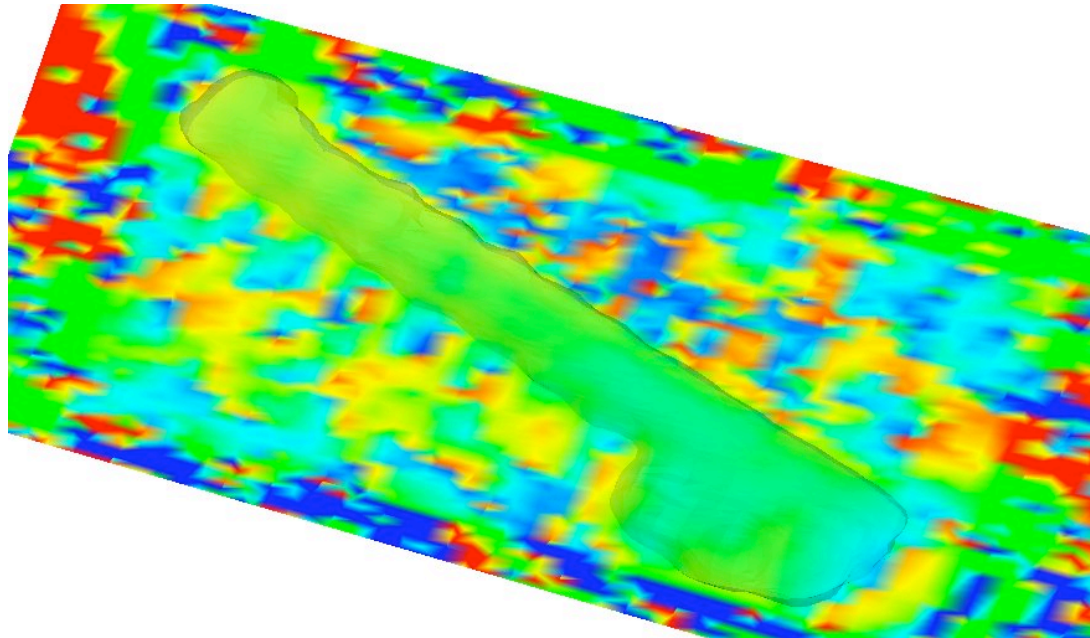

wire

root

May 2009



# GaAs Nanowire “Barcode”

Vincent Favre-Nicolin, Joel Eymery (CEA),  
Rienk Algra (Philips), Ross Harder

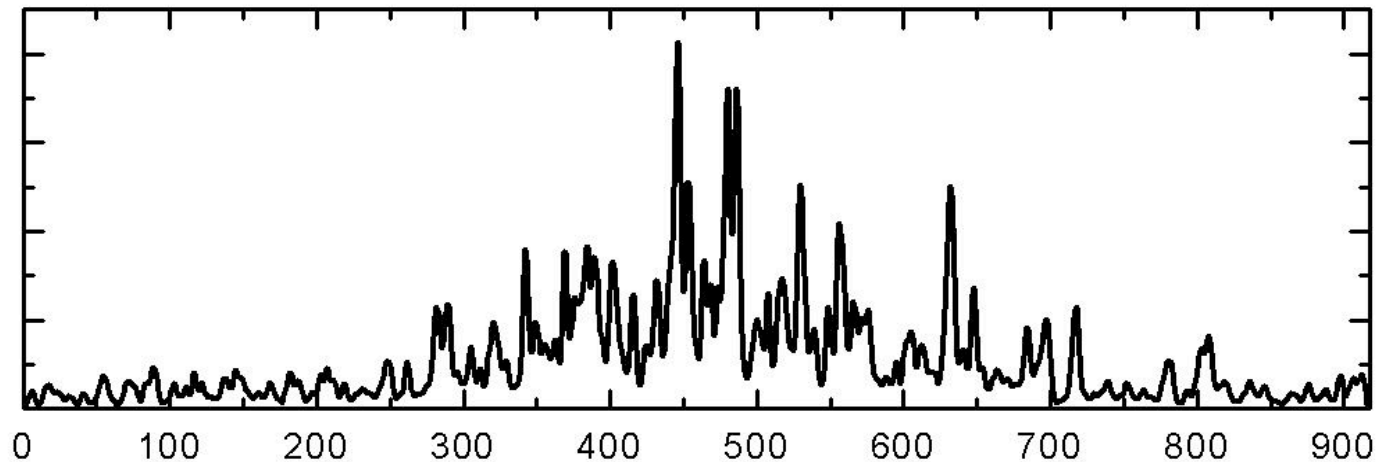
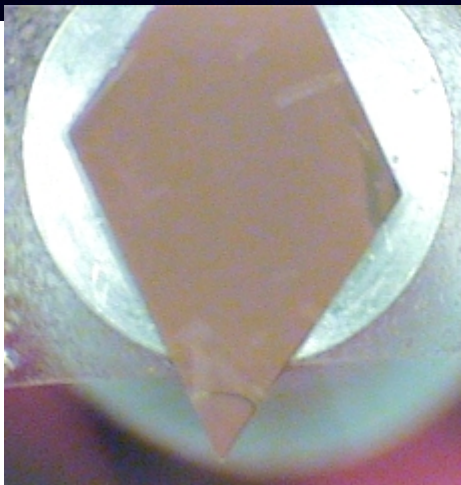
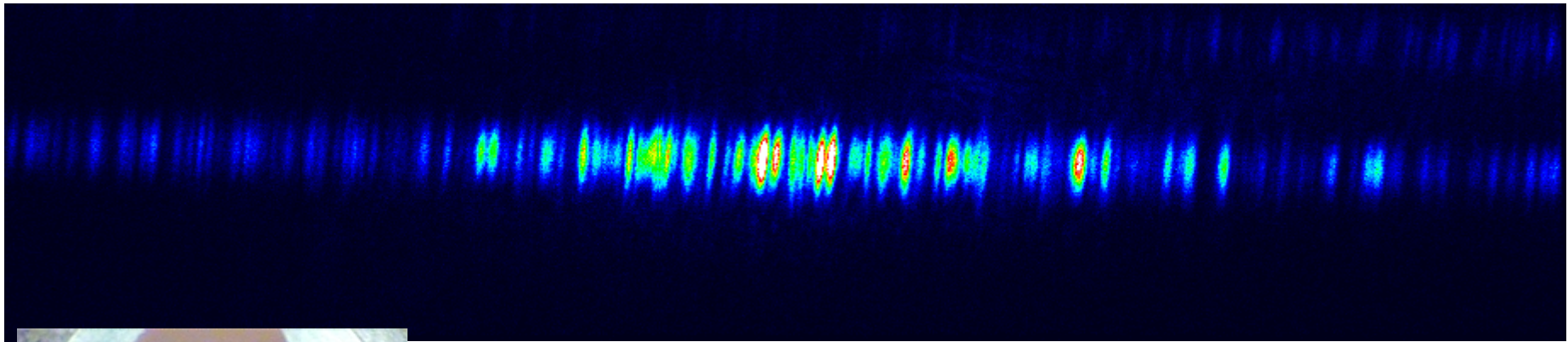

GaAsNW1106-22.spe  
B9348 from Philips

# Dark Field TEM of GaAs Nanowires

R. Banerjee et al, Phil. Mag. Lett. 86 807 (2006)

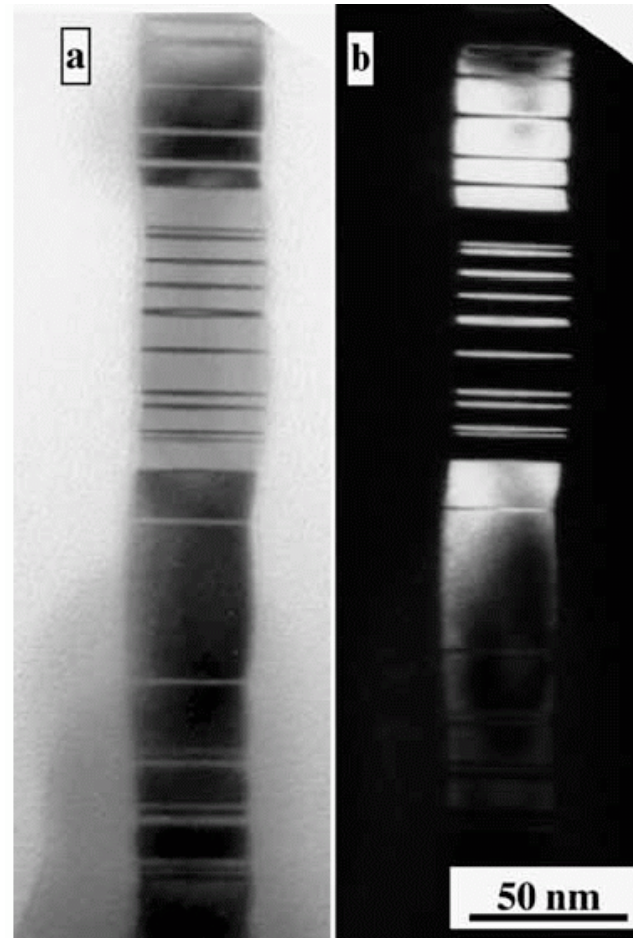
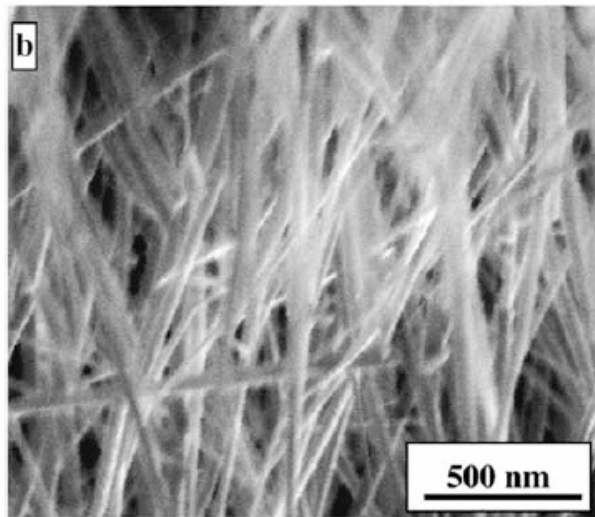
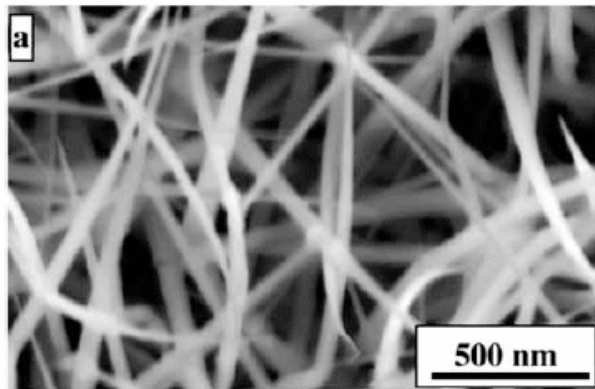



# ZnO Sample Preparation

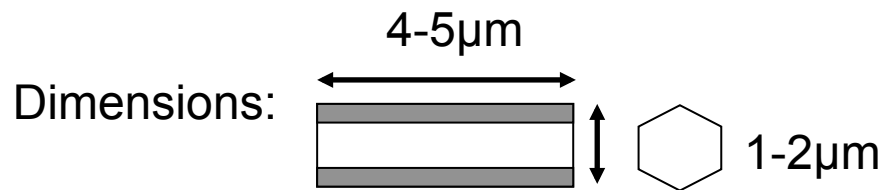
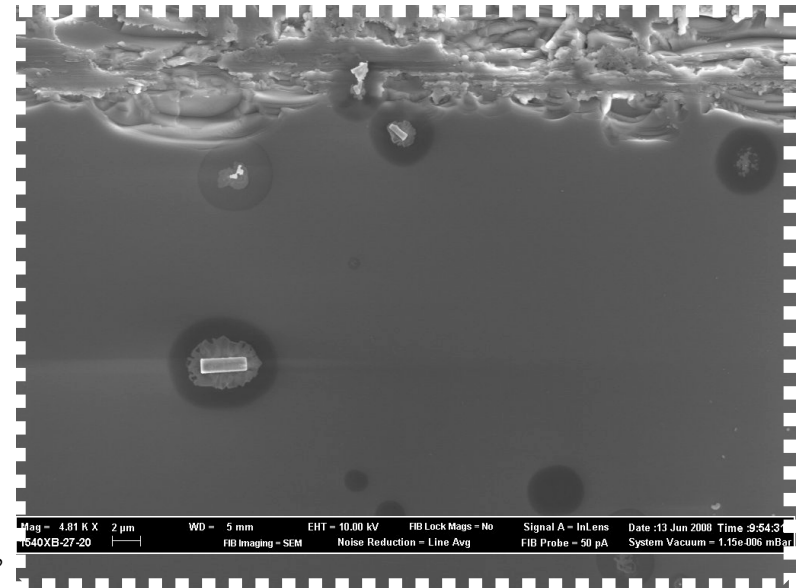
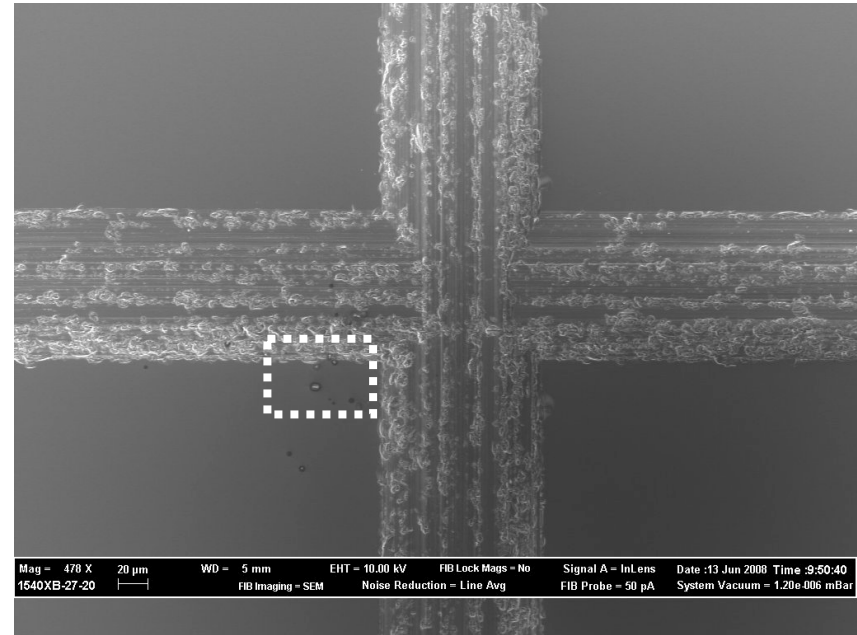
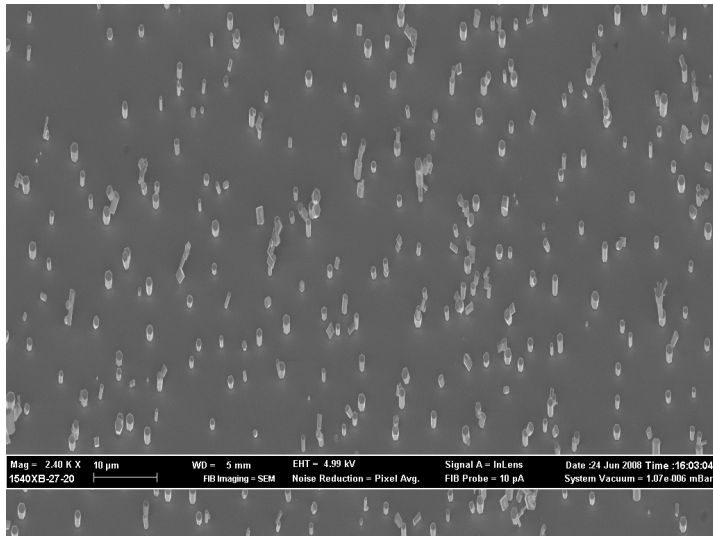

I. K. Robinson, IMM,

# Density sections ZnO-39 (010)

Marcus Newton and Steven Leake (in preparation, 2008)

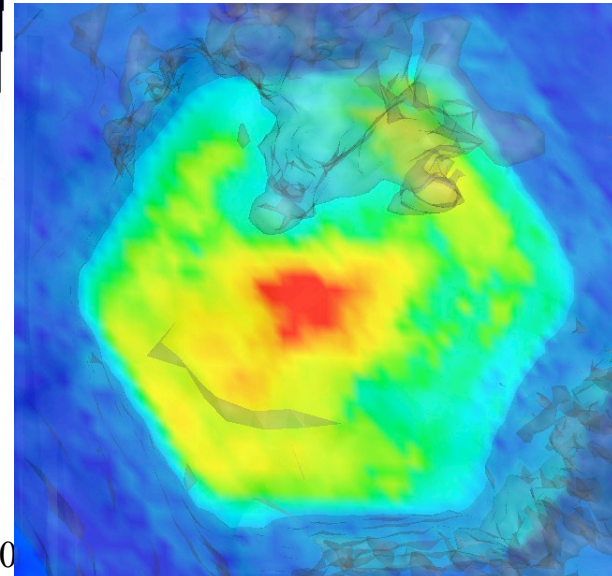
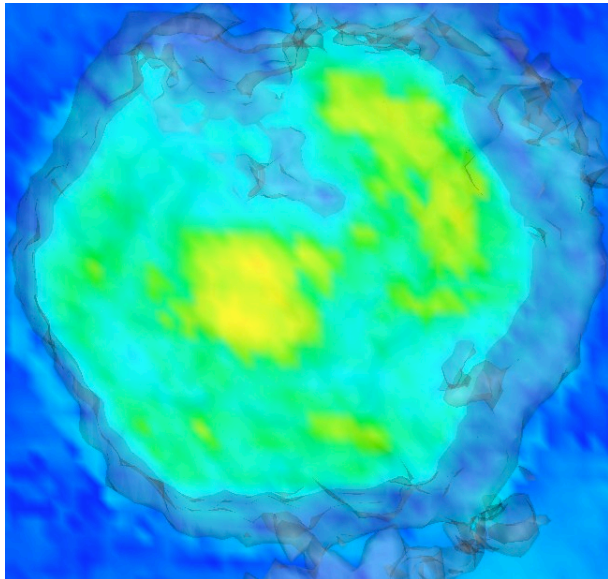
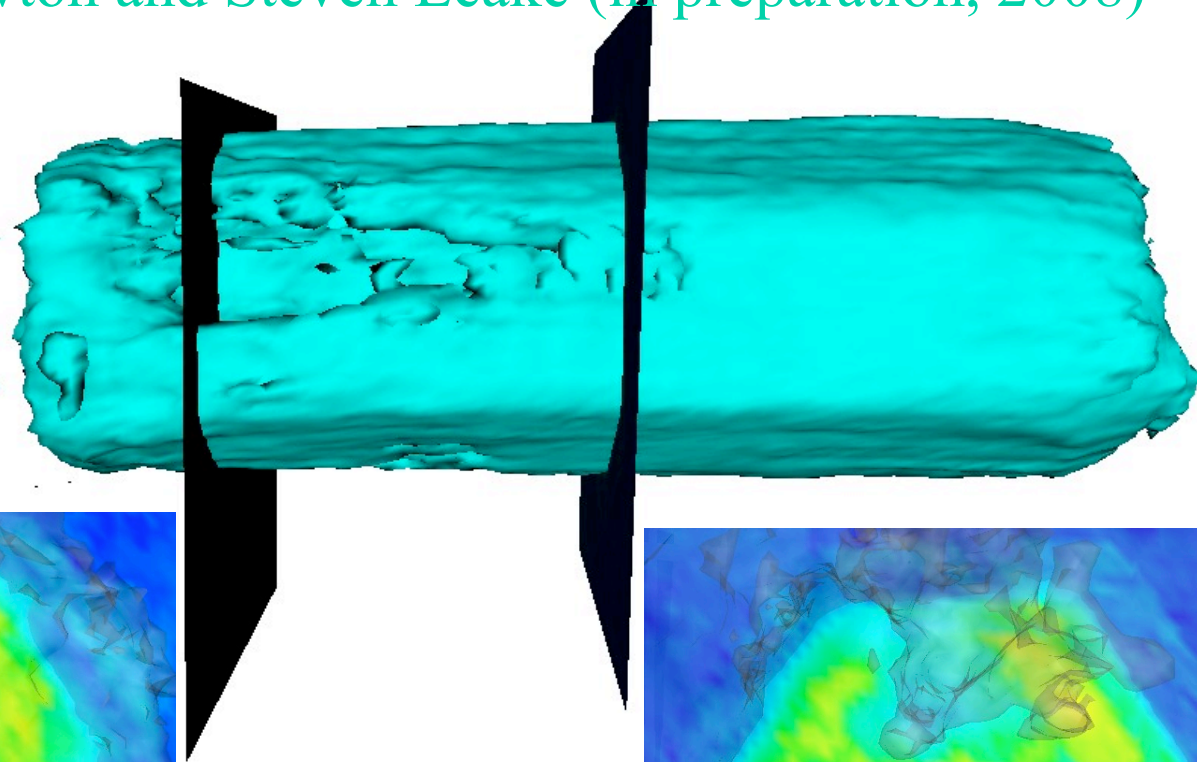

J. K. Robinson, IMM, May 2008

# Phase maps from 2 Bragg peaks

Blue-Red is +2 radians. Slice at -1500nm from centre ZnO-5 -39

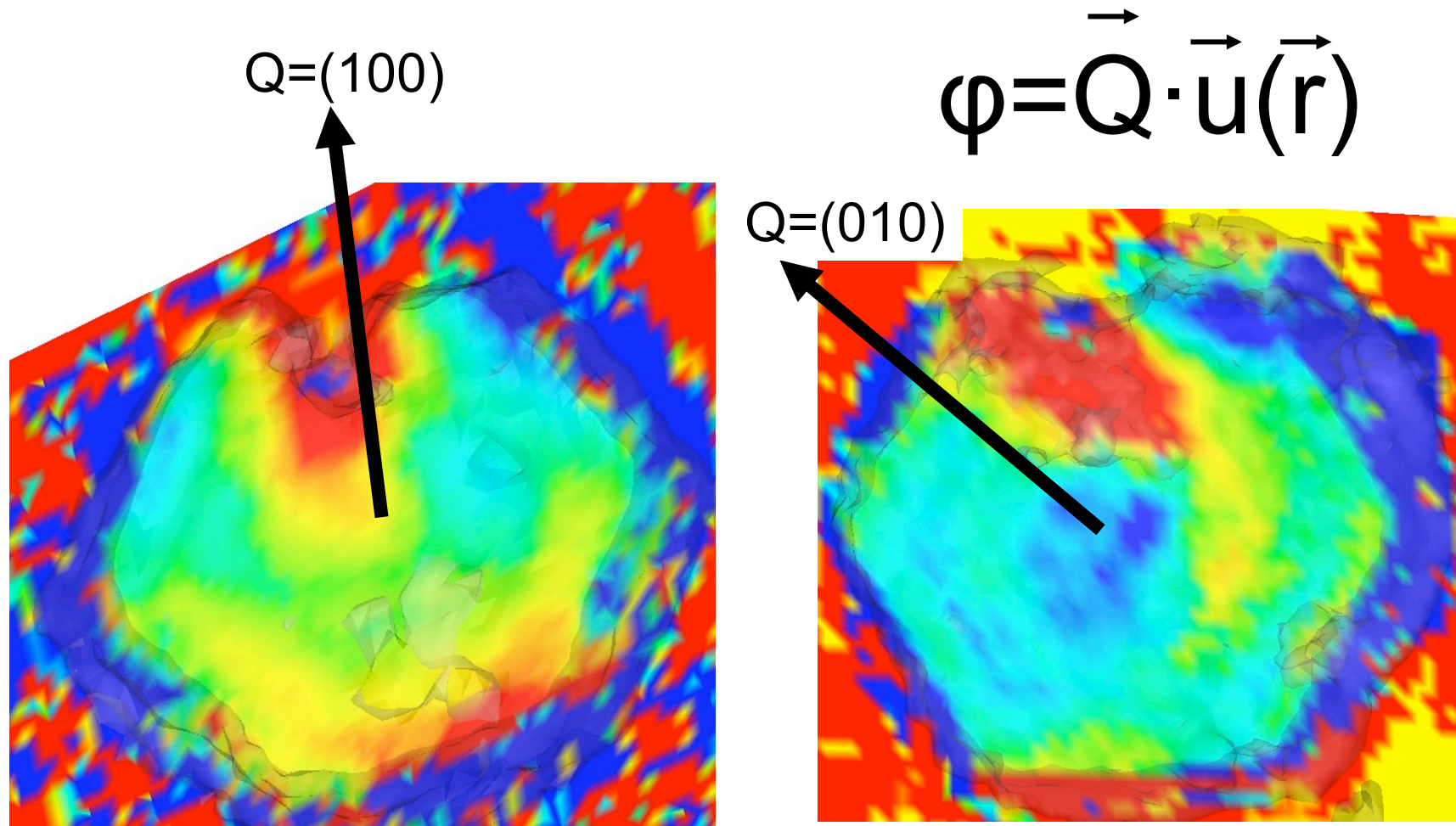

# Typical displacement field

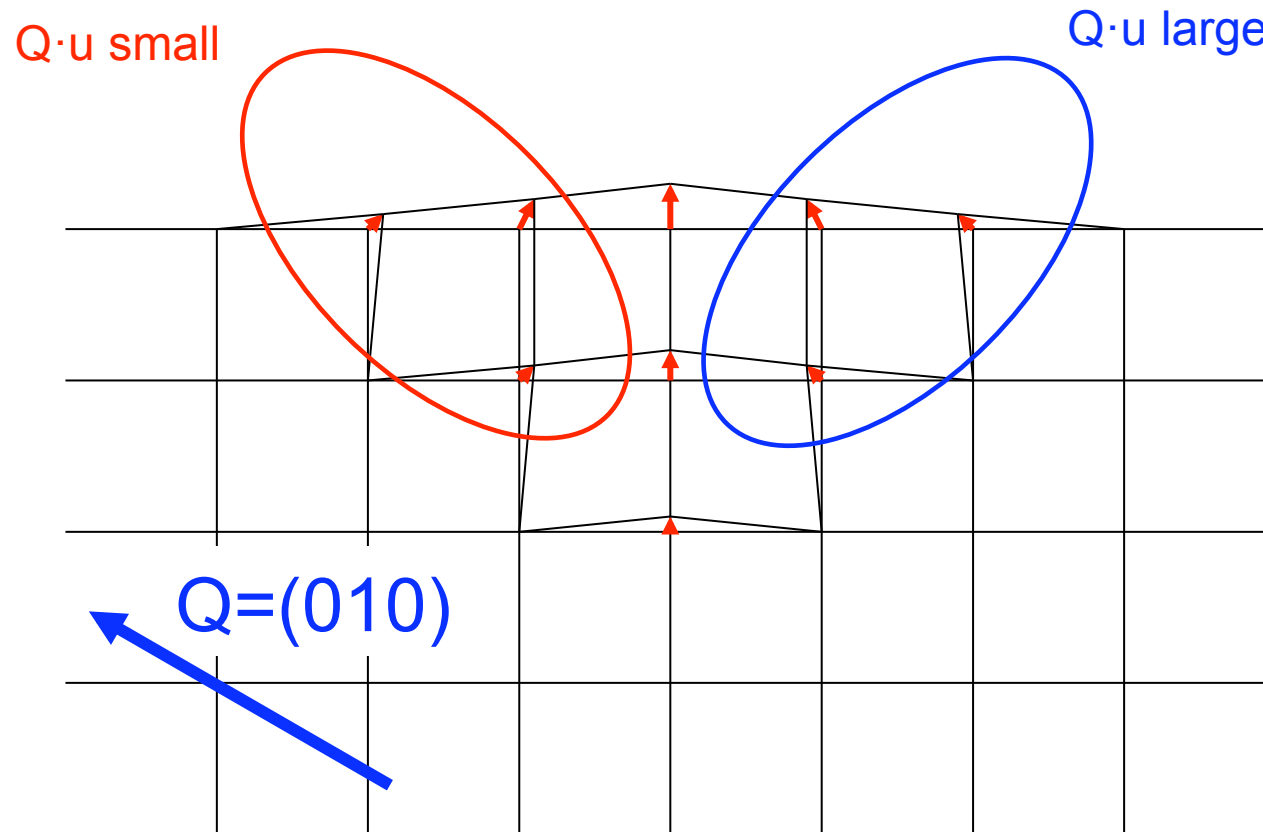

# Strain and Rotation fields

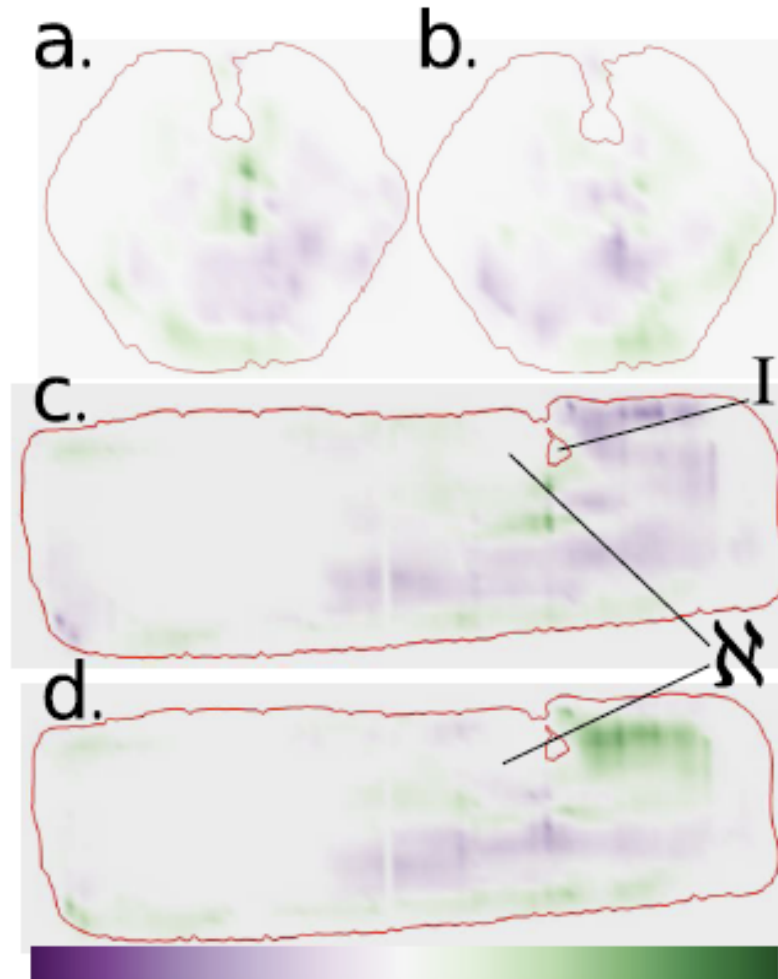
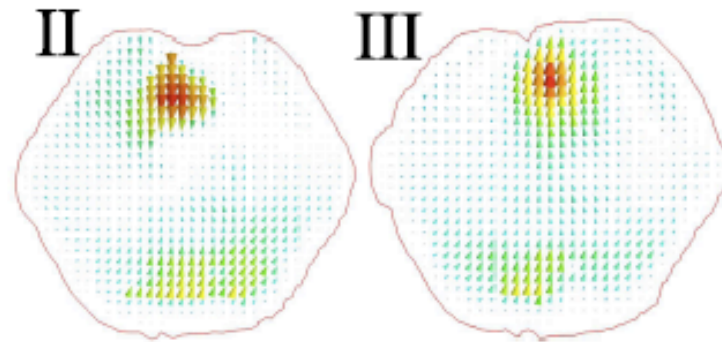
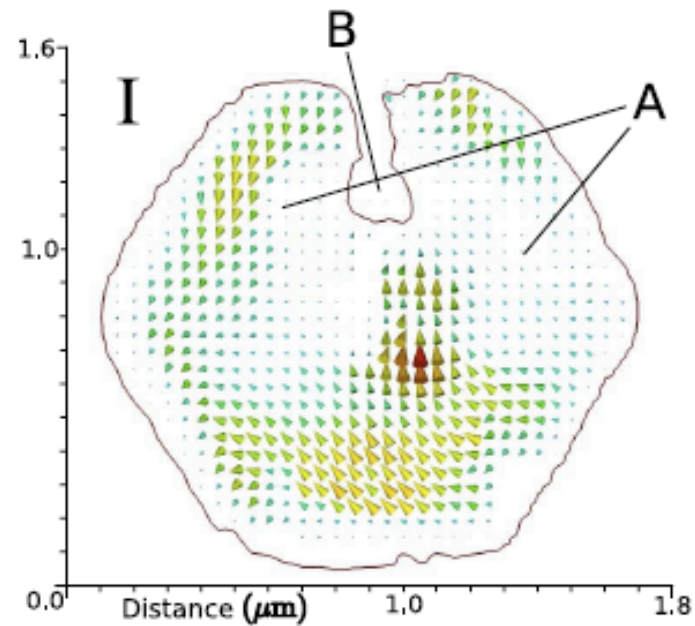

# Nanocantilevers

Dr Rachel McKendrie

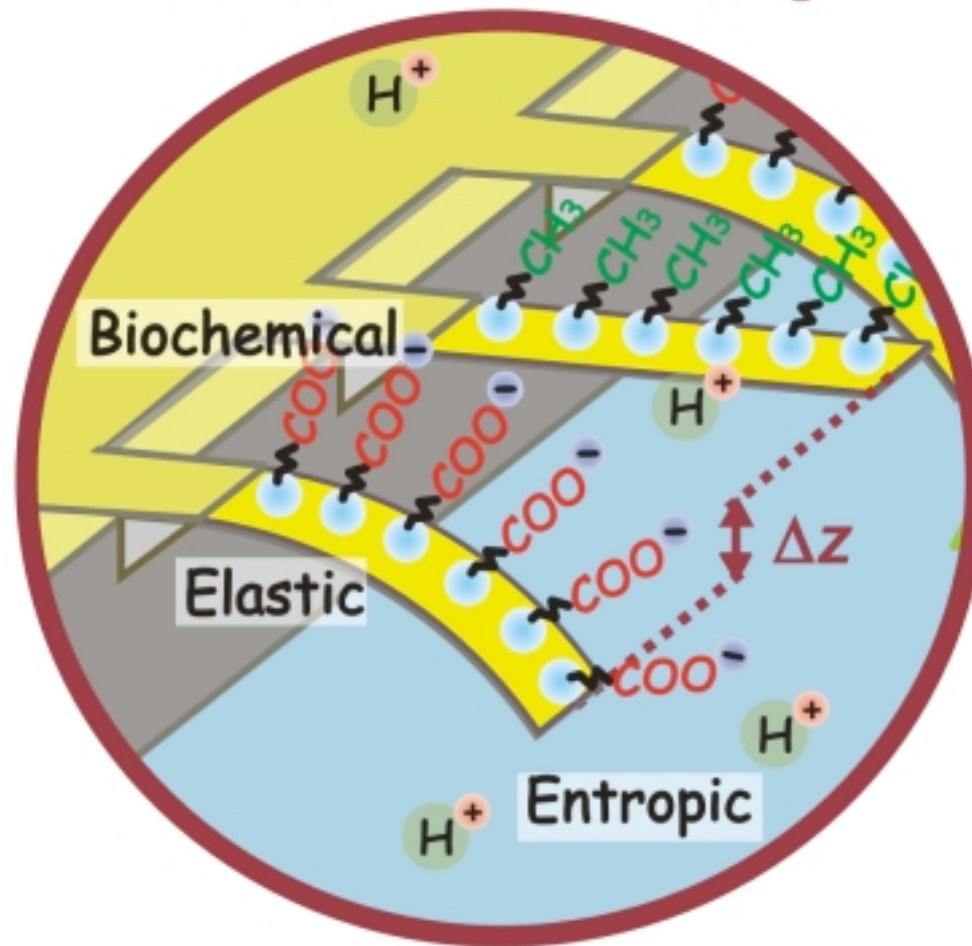

# Strain induced by thiol binding

Moyu Watari, UCL, Oct 2008

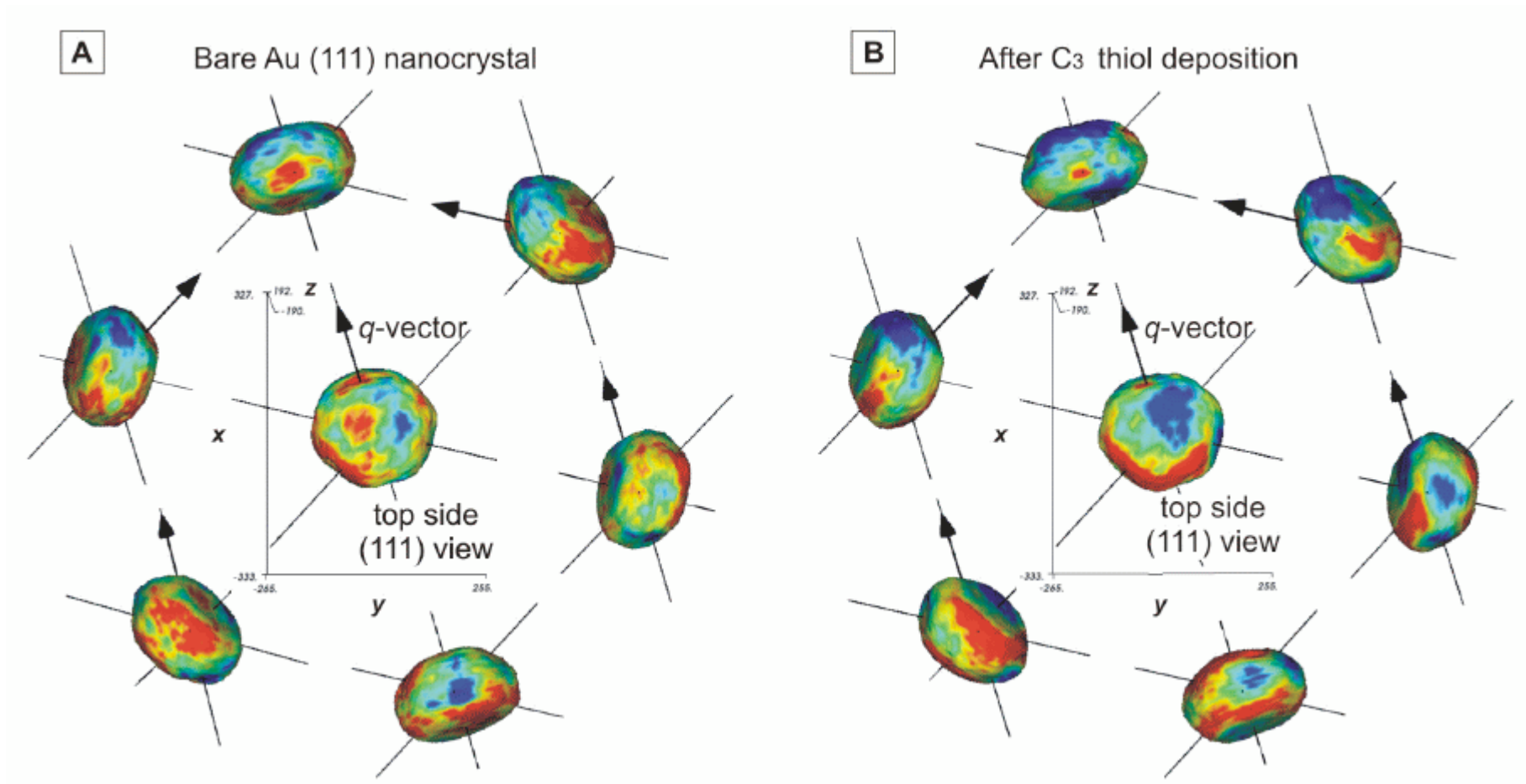

# Molecular Movies using XFEL



# Single-molecule diffraction

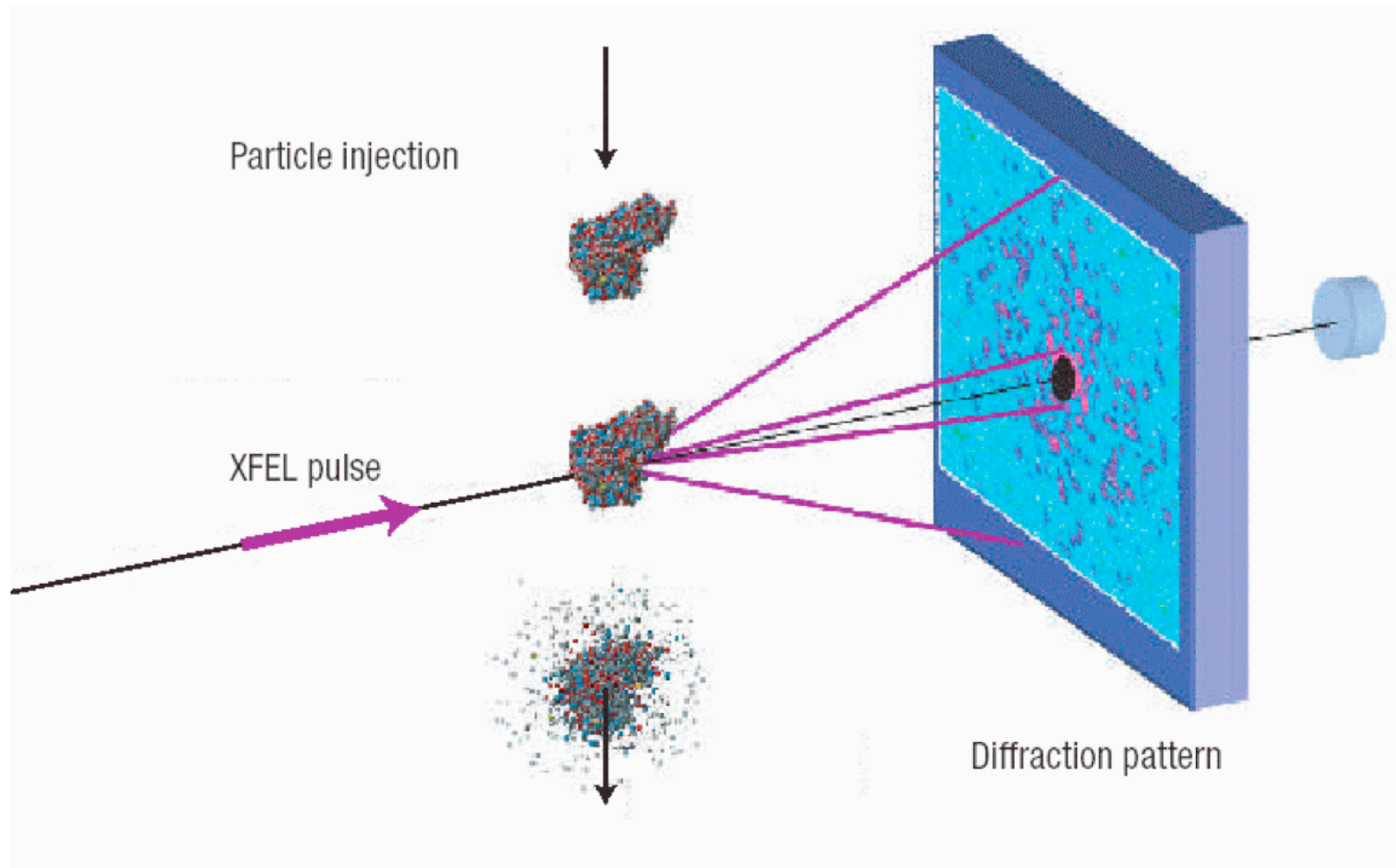

# How much information in a single shot?

- Phase problem can be solved beforehand:
  - Low dose rocking curve before ‘shot’
  - Ptychography scan before ‘shot’
- Phased diffraction allows full imaging during transient
- Phases are little changed during perturbation
  - localised change in real space affects all of reciprocal space
  - traditional “difference map” principle

# Planning for initial LCLS experiments

- CXI and PCS not ready in initial phase
- XPP will be first diffraction station
  - Area detector can measure CXD pattern
  - Laser pump can ‘activate’ sample
- Fabricated Gold nanocrystal arrays
  - control size, shape, orientation (est 200nm)
- Pre-align each under low dose for phasing
- Explode with full pulse, same or not?
  - Observe melt? front after laser pump

# e-beam Lithography “Lift-off” method

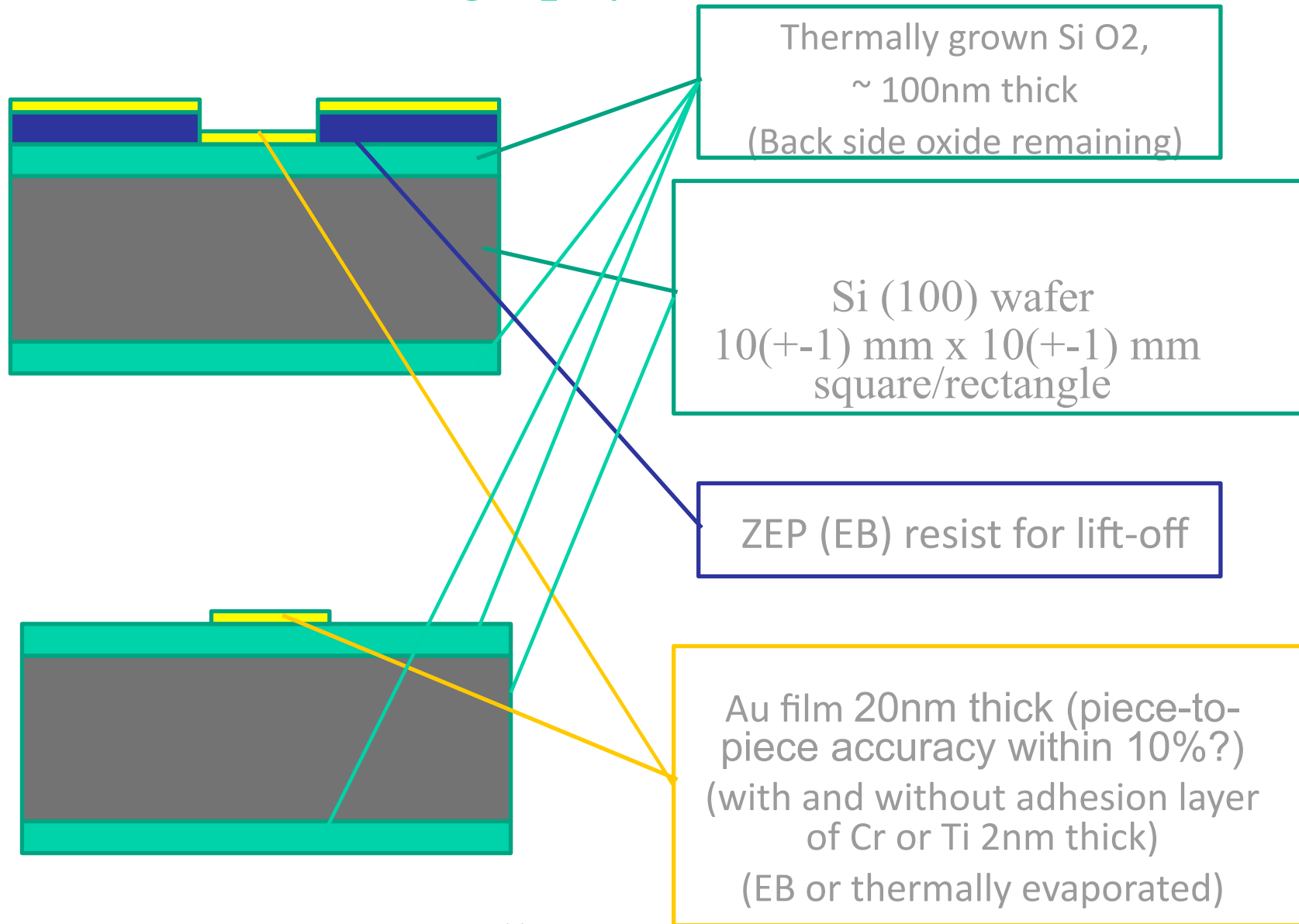

# Top View of basic layout plan with pickup marks

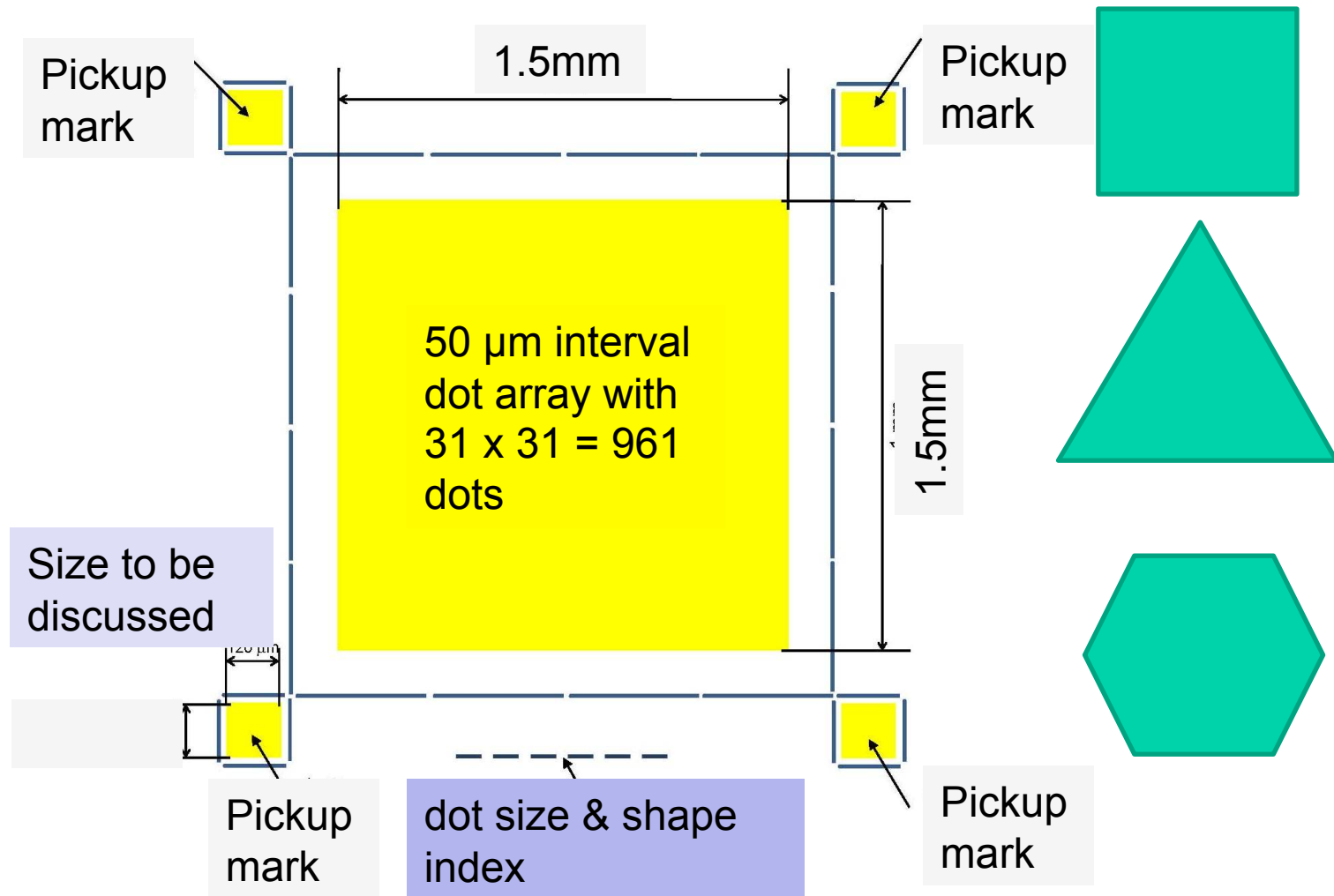

# Top View of chip layout

S. Shimamoto (Waseda), T. Matsuura (UCL), Sept 2008

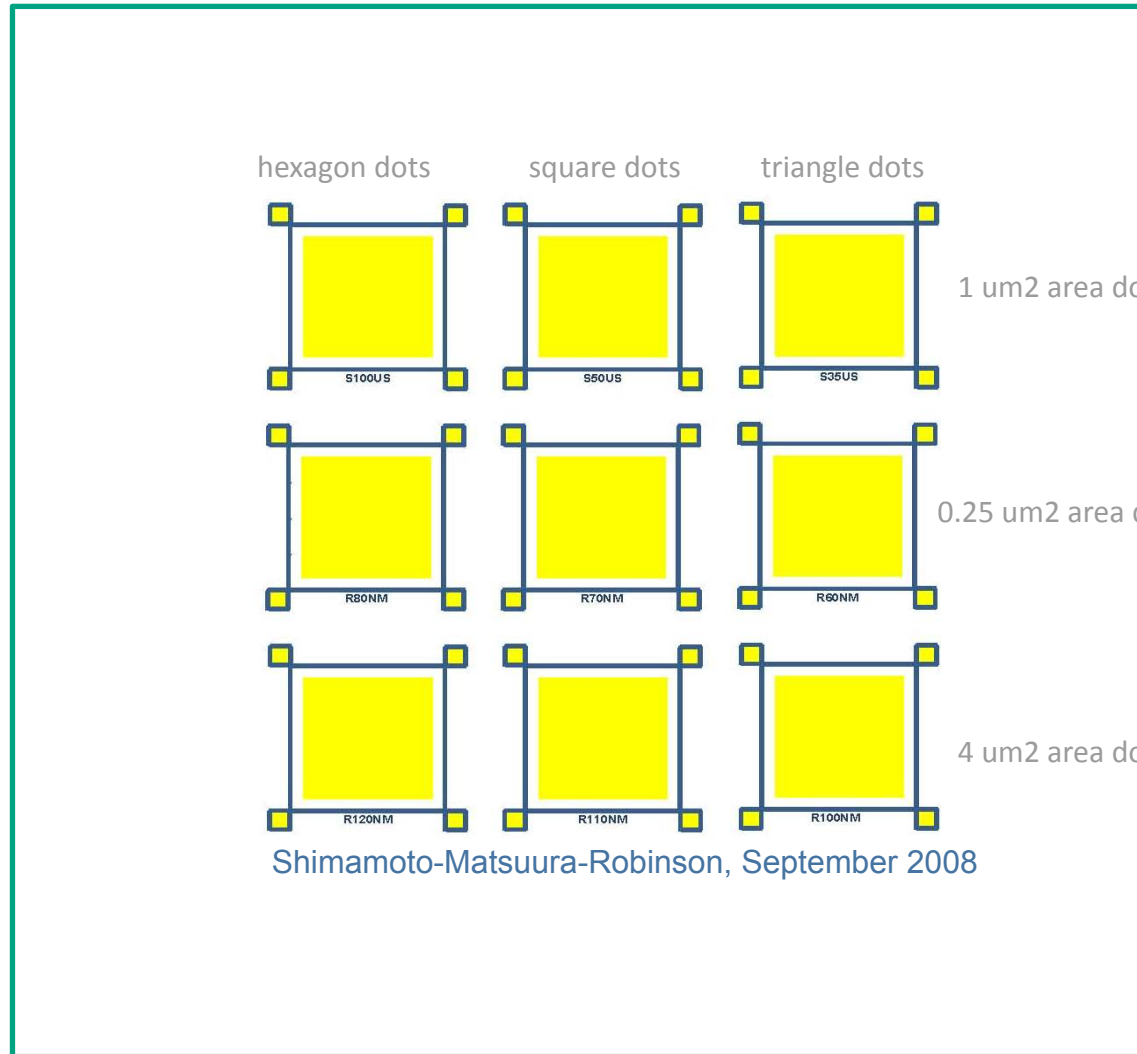

# Single Au nanocrystal synthesis

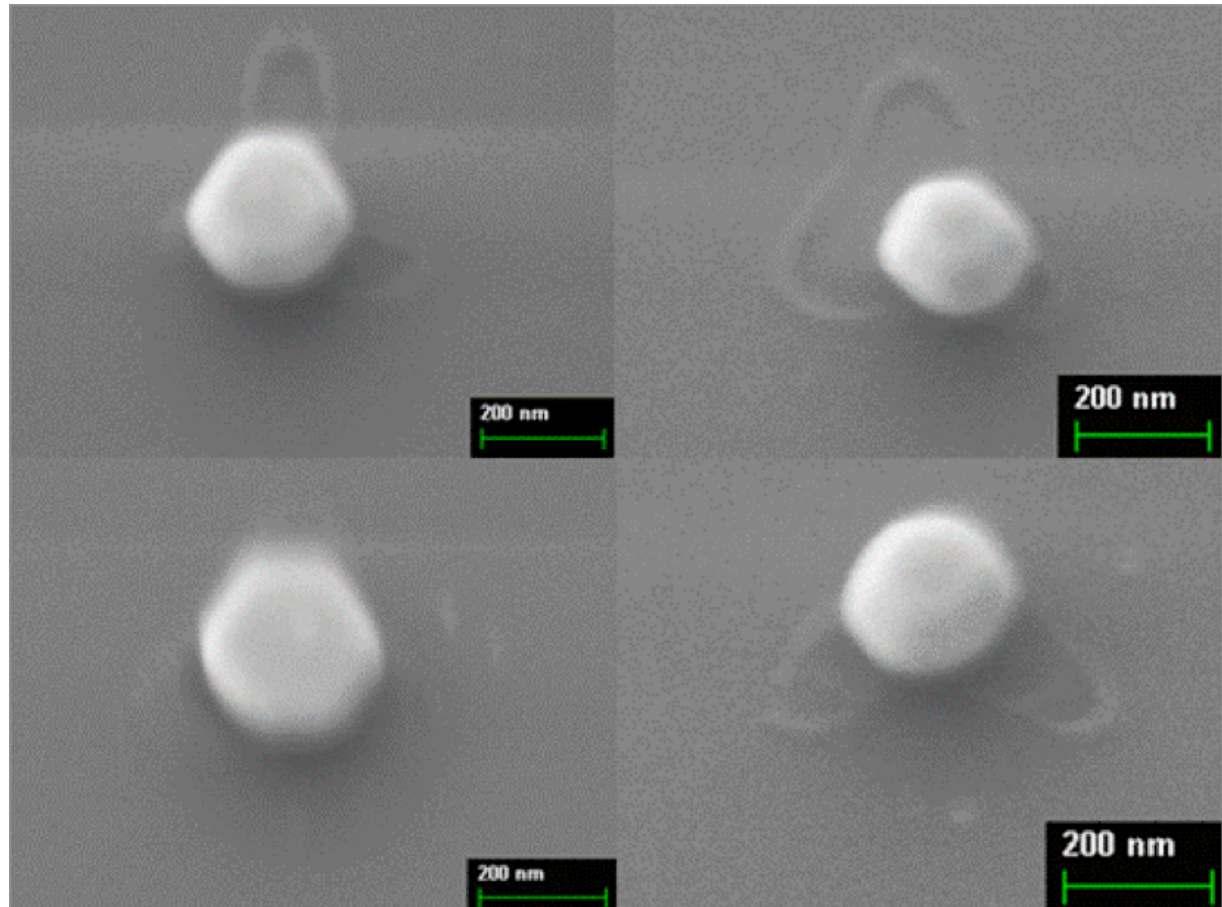
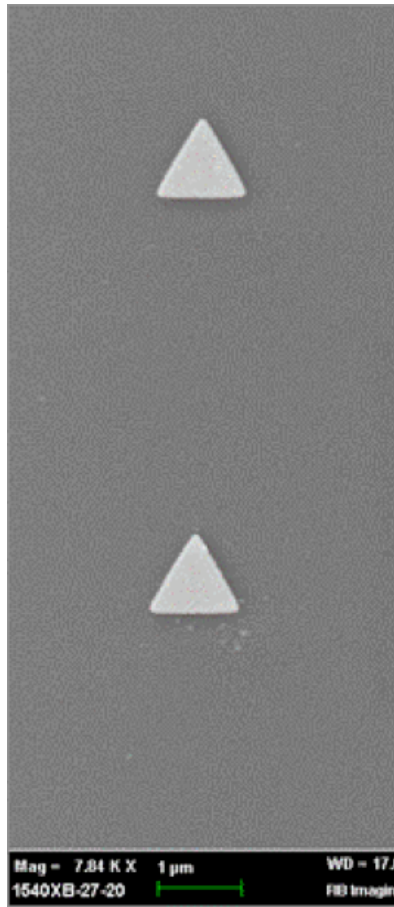

# Two views of strain in Au NC

Au409B-52 (11-1) and Au409B-60 (200)

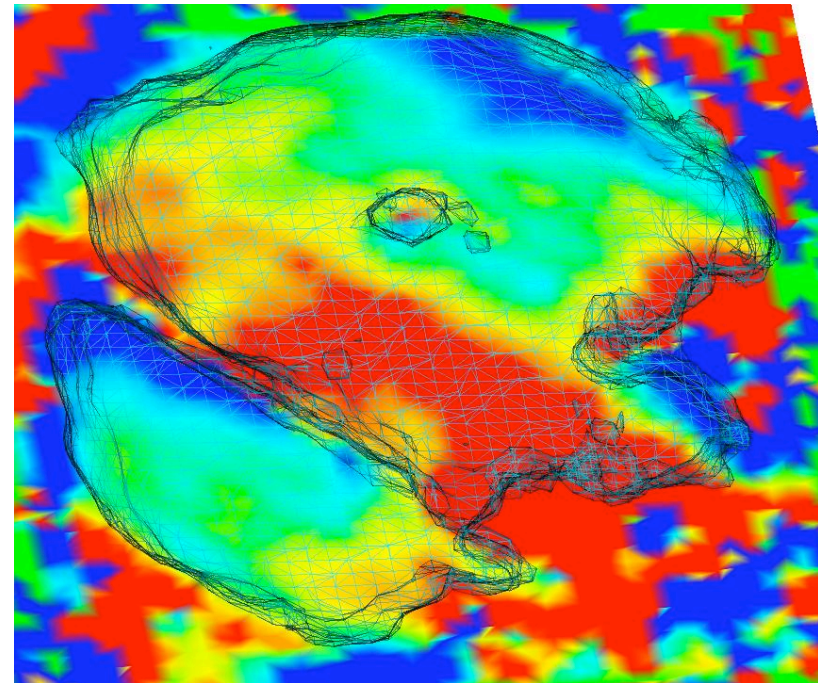
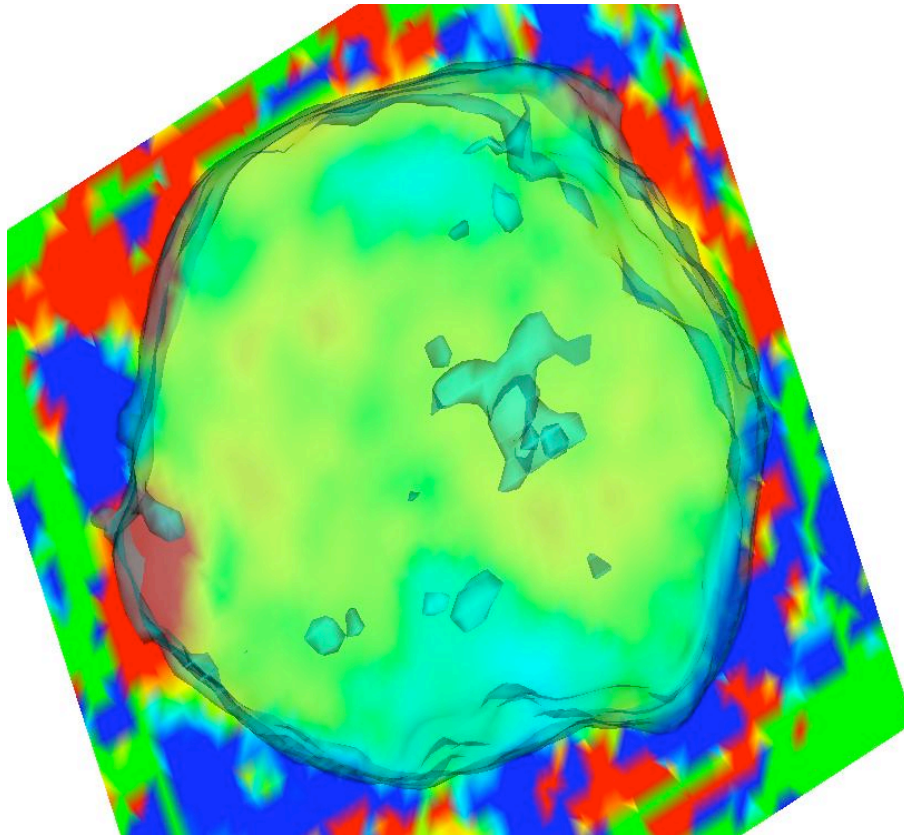

# Conclusions

- Coherent x-ray diffraction
- Nanocrystal images at 40nm resolution
- Imaging of strain fields
- Nanowires have internal faults
- Possibility to beat radiation damage
- Preparations for shock wave experiments