

Coherent X-ray Diffraction Methods in Biology

- Ian Robinson
 - Sébastien Boutet
 - Franz Pfeiffer
 - Ivan Vartanians
 - Ross Harder
 - Meng Liang
 - Garth Williams
 - Mark Pfeifer
 - Jing Tao
 - Jim Zuo
- London Centre for Nanotechnology,
University College London
Diamond Light Source
(ex University of Illinois)
- Astbury Seminar
Leeds University
October 11th 2007

Synchrotron Radiation

Urbana

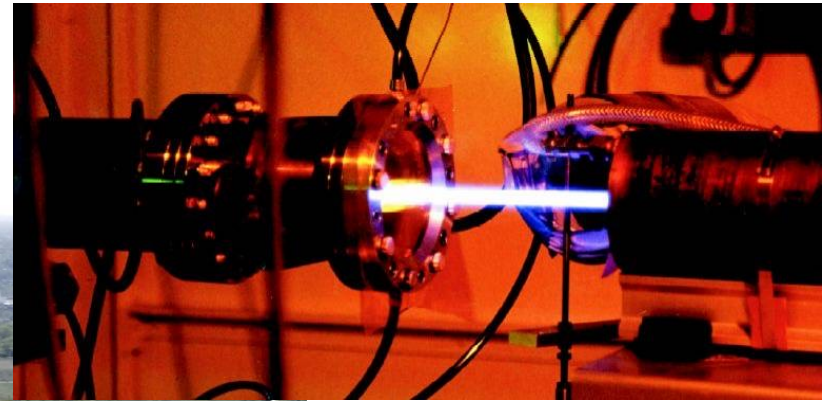

34-ID-C



Diamond Light Source (RAL)



I. K. Robinson Astbury 2007

Last Girder – March 2006



I. K. Robinson Astbury 2007

“First Light” - May 2006

ramped to 3GeV – Sept 2006

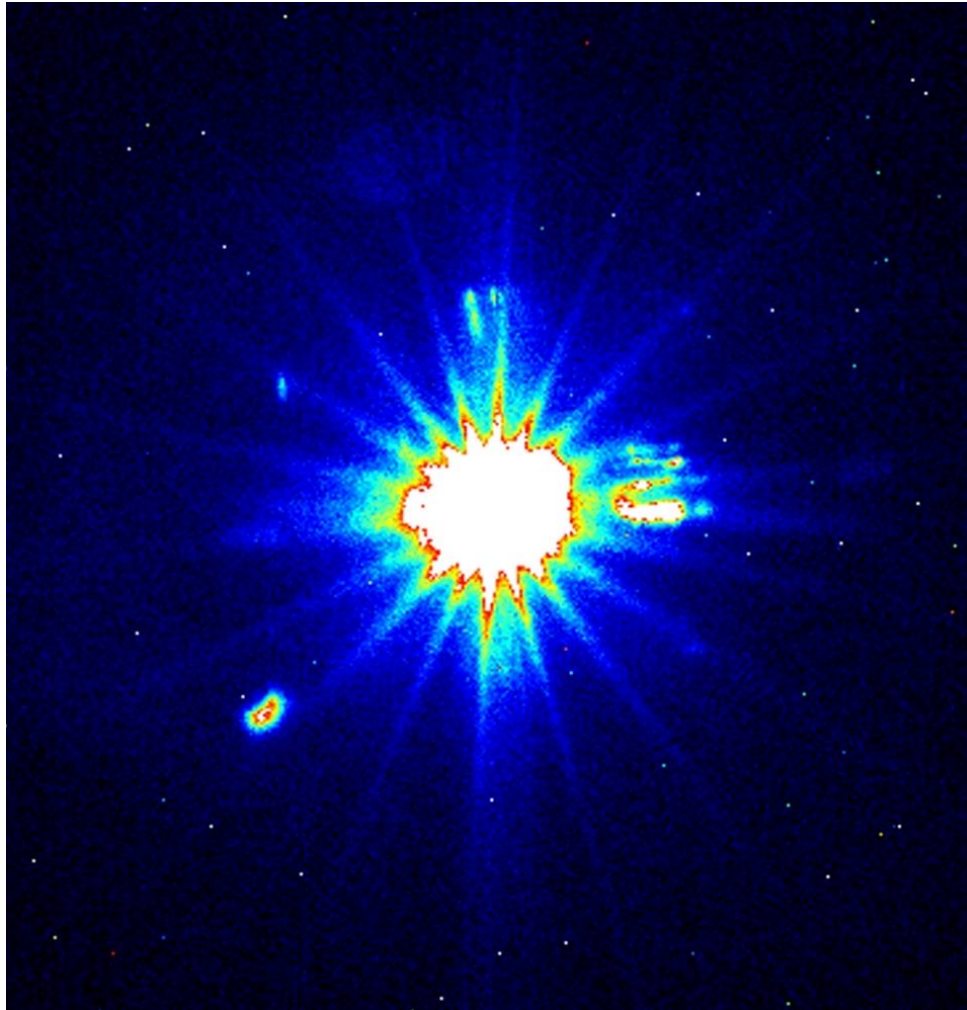

I. K. Robinson Astbury 2007

Typical beamline: I-22



I. K. Robinson Astbury 2007

Diamond
in-vacuum
X-ray
Undulator

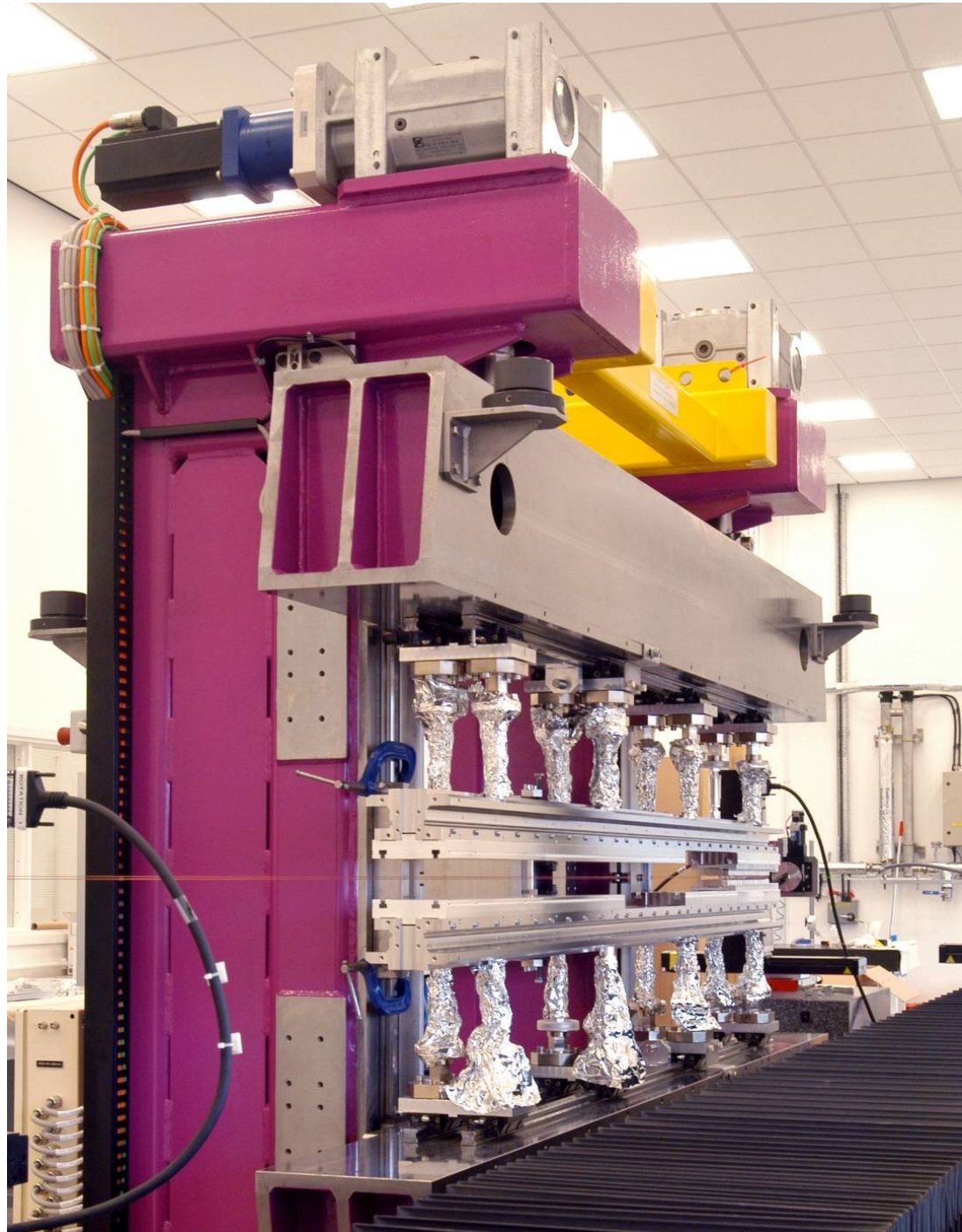

X-ray Undulator Principle

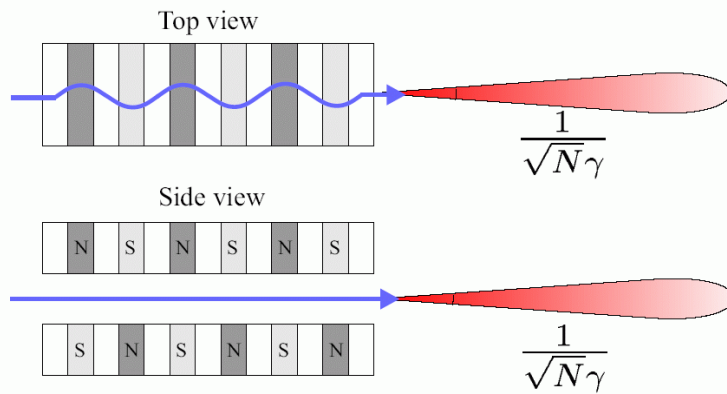

$$\lambda_X = \frac{\lambda_U}{2\gamma^2} \left\{ 1 + \frac{K^2}{2} + (\gamma\theta)^2 \right\}$$

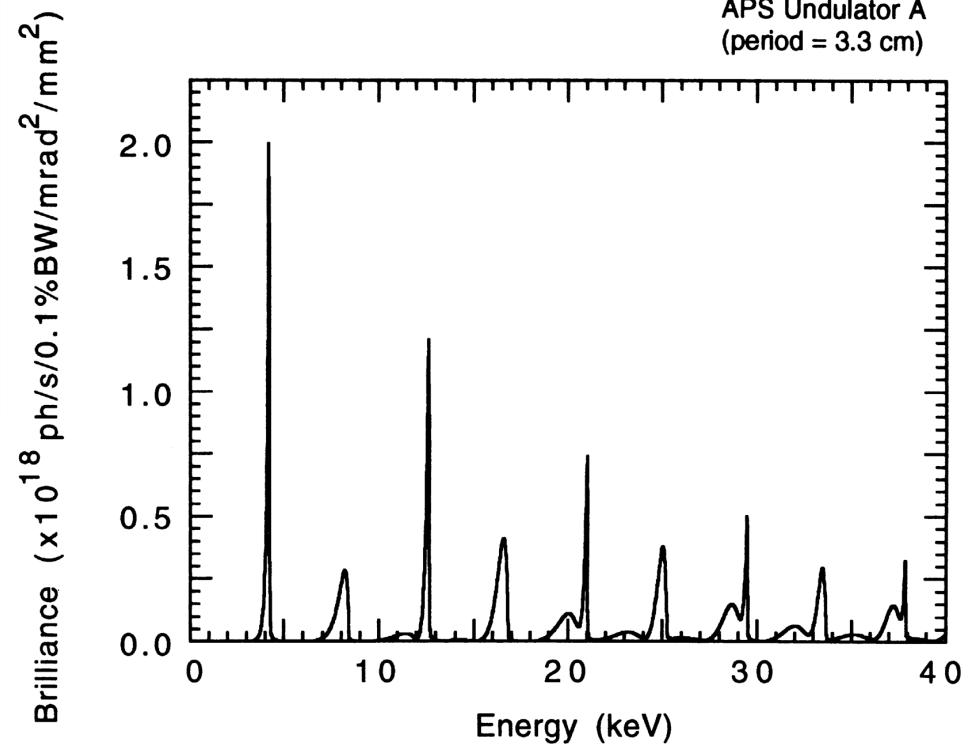

Tomato Bushy Stunt Virus 1980

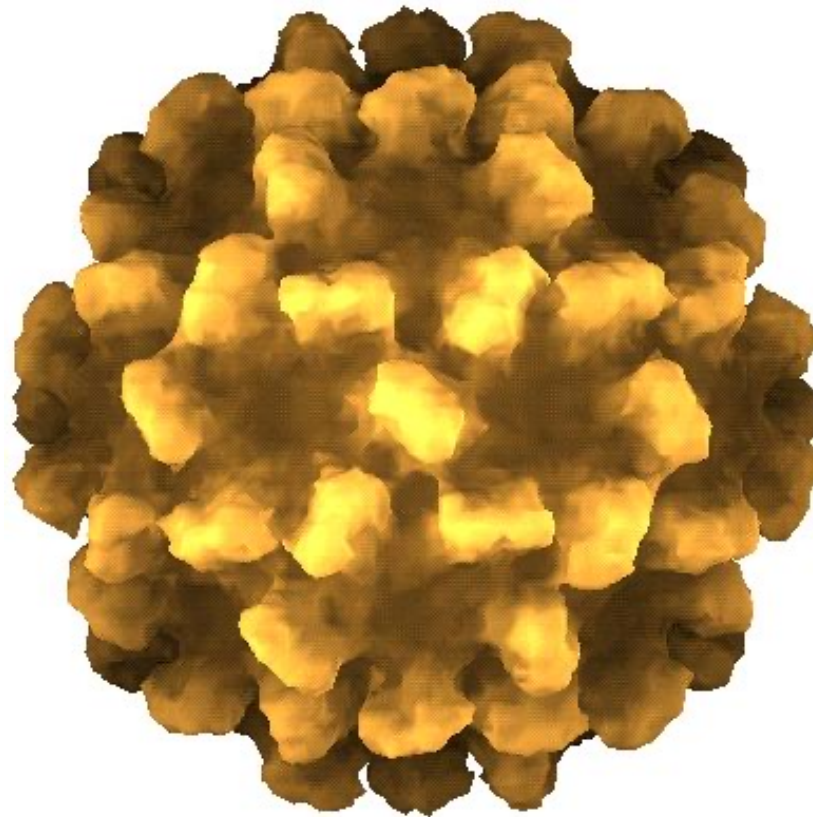

I. K. Robinson Astbury 2007

Horse Spleen Ferritin

- Ferritin used in almost all living things for Iron Storage
- Made of 24 identical protein subunits arranged in 432 symmetry
- Crystallizes as FCC (I23)
- Inner shell diameter 80Å
- Outer shell diameter 130Å
- Iron core: ferrihydrite form
- With Iron : **Holo**ferritin
- Empty Shell : **Apo**ferritin

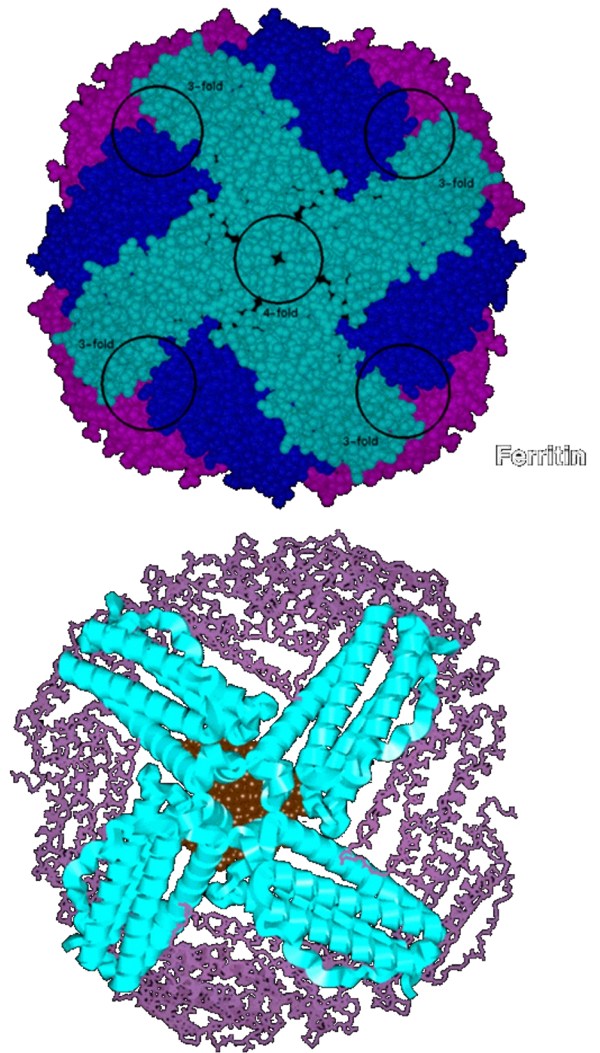

Critical Nucleation

Yau S.-T. and Vekilov P.G., *J. Am. Chem. Soc.* (2001), 123, 1080-1089

- a) Nucleation via planar 2D clustering
- b) Nucleation via compact close-packed 3D clustering
- Possible also via non-crystalline (eg icosahedral) nuclei.

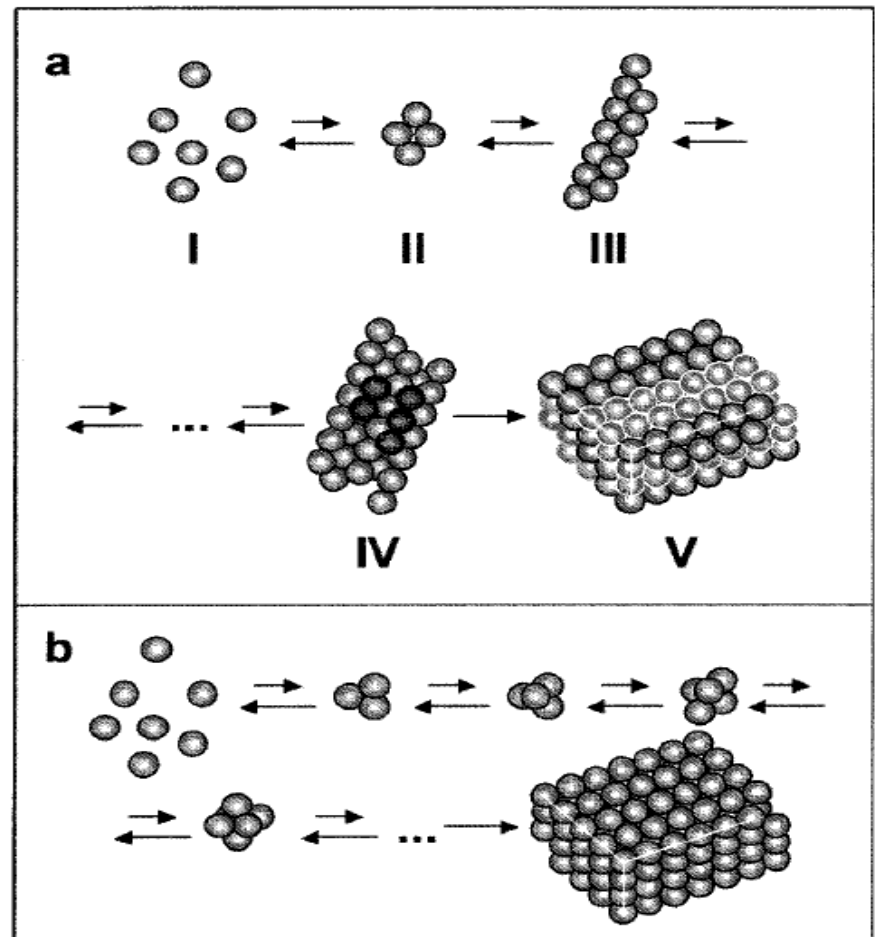
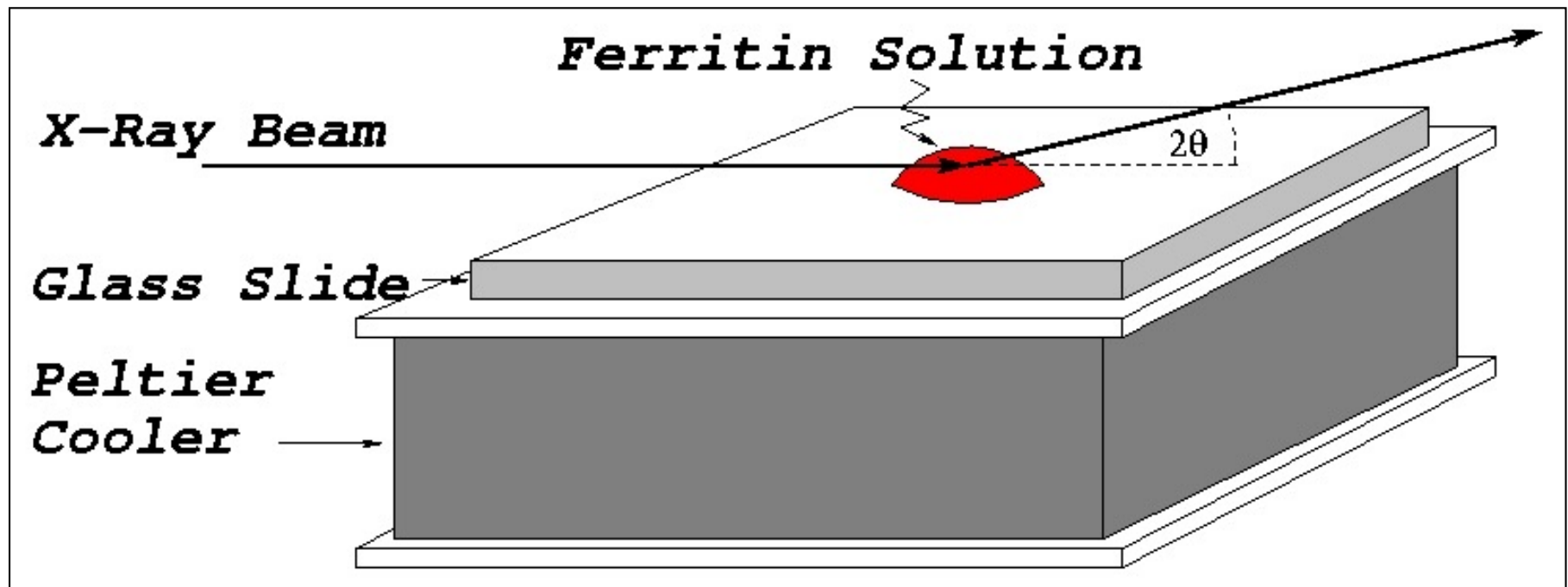
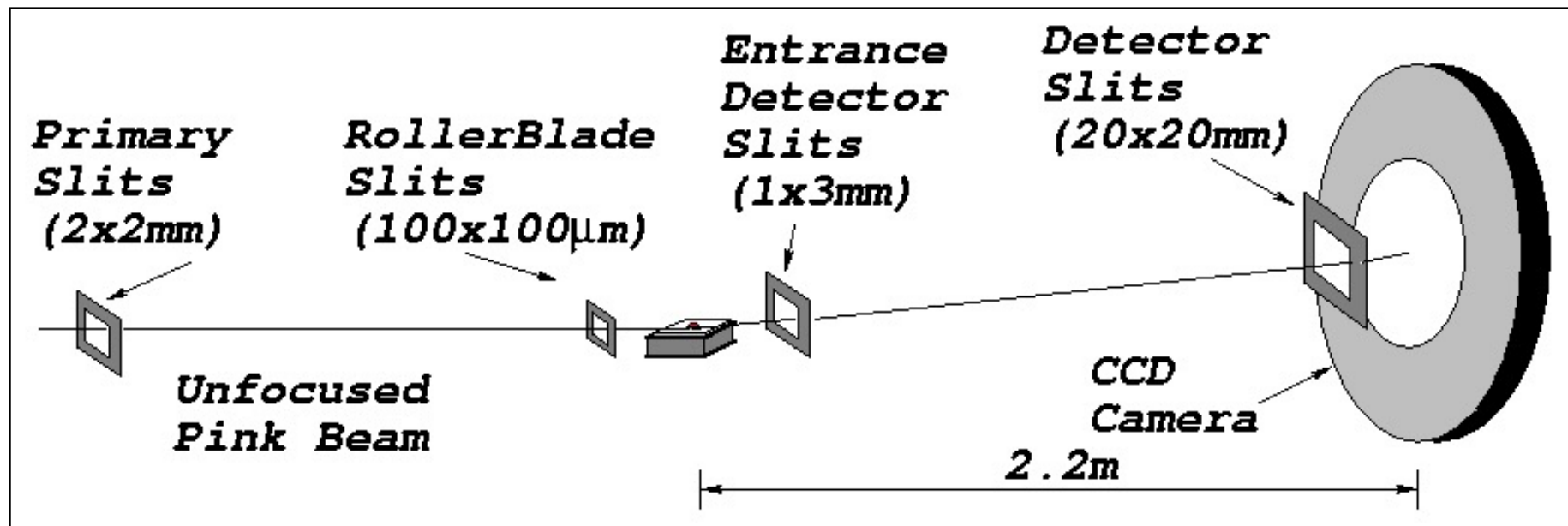

Figure 10. Schematic illustration of two nucleation pathways: (a) via a planar critical cluster (in IV molecules belonging to the second layer are shown in a lighter shade; in V the (110) layers that stack up to form this crystal are delineated by lighter and darker contours) and (b) via compact critical cluster.^{5,6}

In-situ Study of Crystallization



Experiment at APS Sector 34



Crystallization of Holoferitin: SAXS

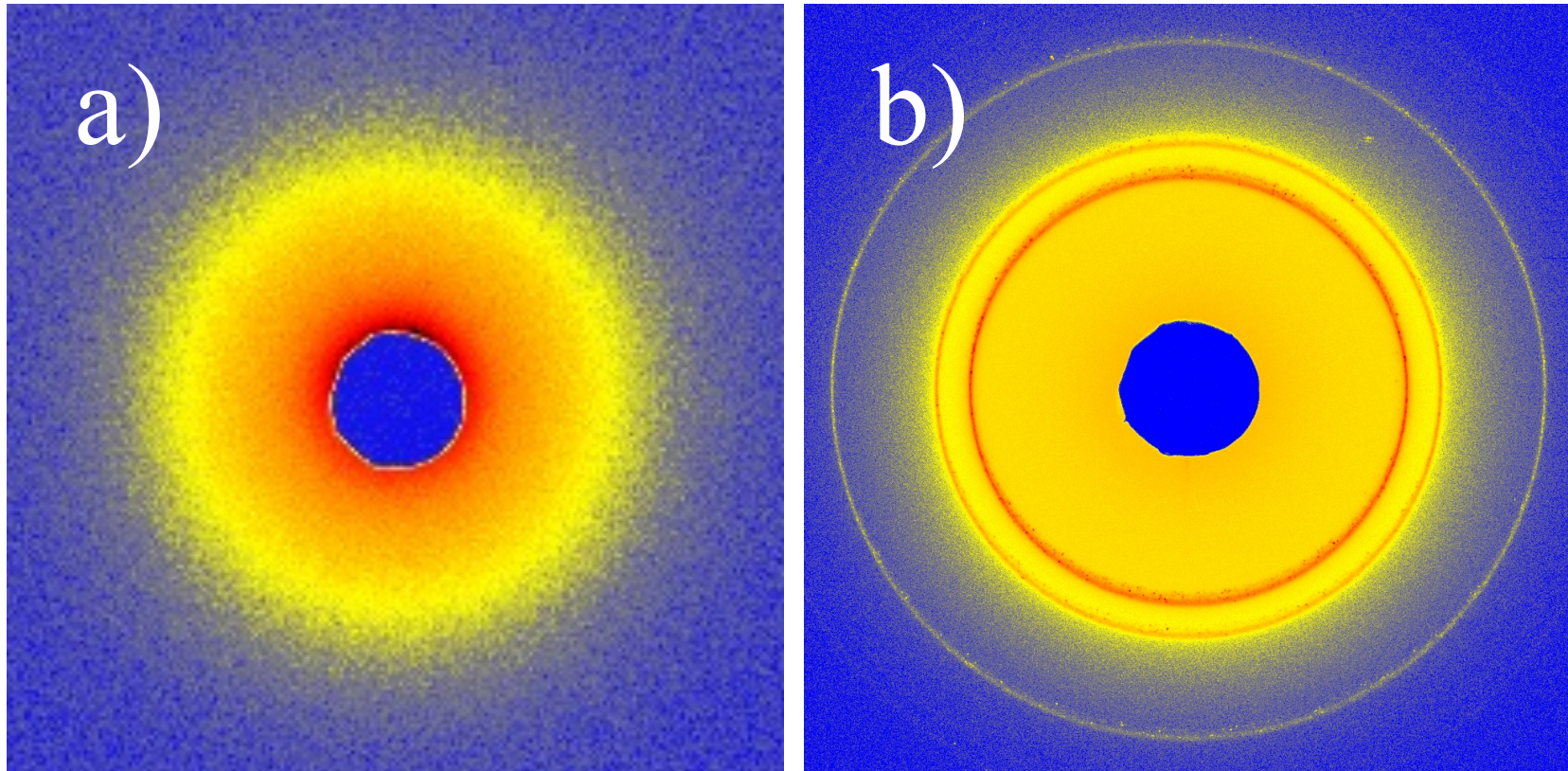

a) SAXS pattern of holoferitin at 10°C.

b) SAXS pattern after adding Cadmium salt

Effect of Temperature

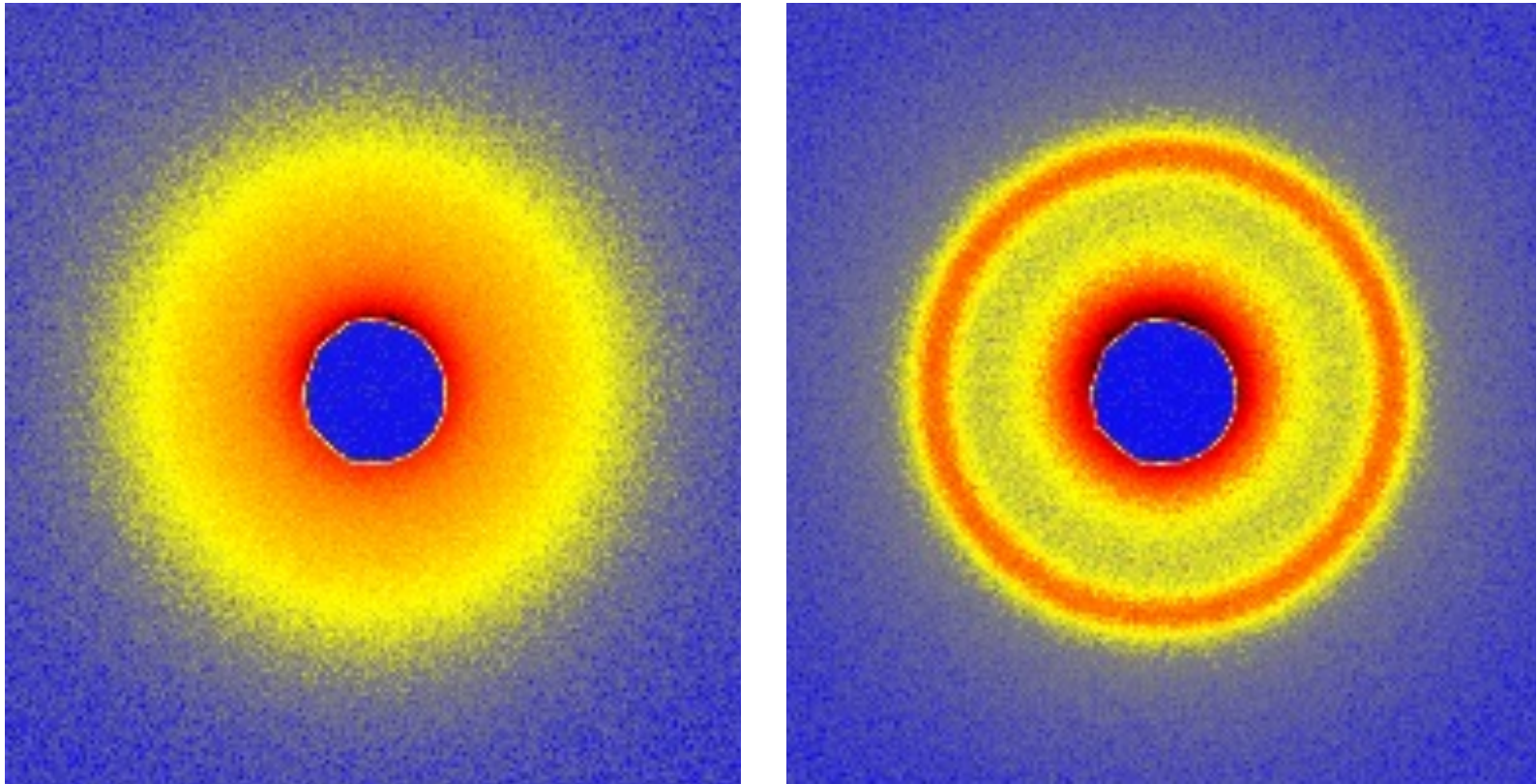

SAXS pattern at $T=+10^{\circ}\text{C}$ and -10°C .

Holoferritin in dilute (10mg/ml) NaCl only.

I. K. Robinson Astbury 2007

Integrated SAXS Data

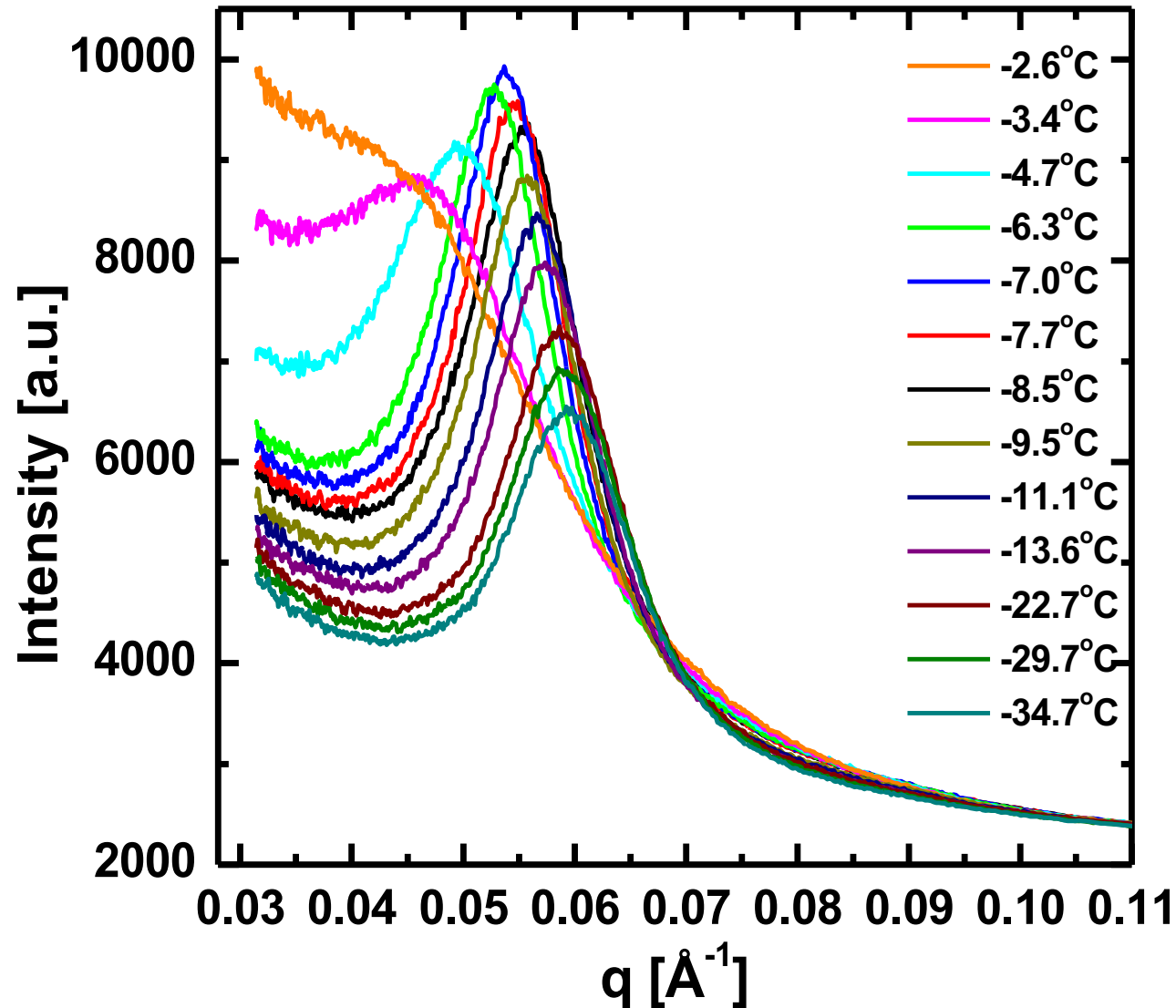

- The SAXS pattern shows a broad peak which shifts in position and changes in width as a function of temperature

Ferritin Solution upon Freezing

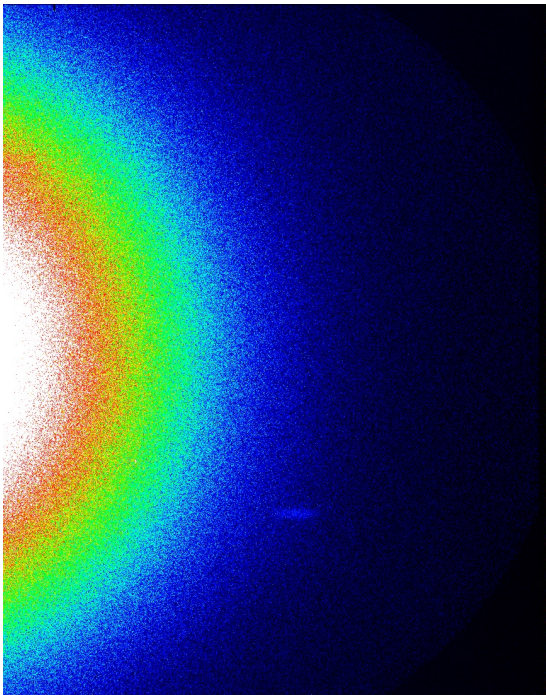

T=13.3

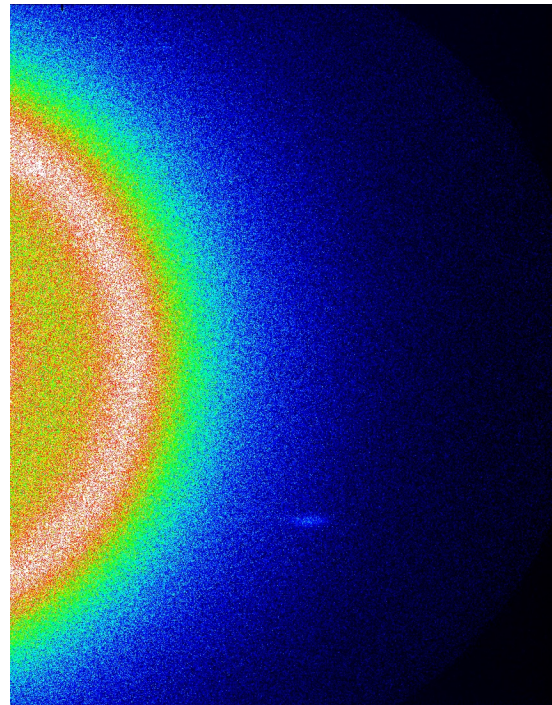

T=-4.7

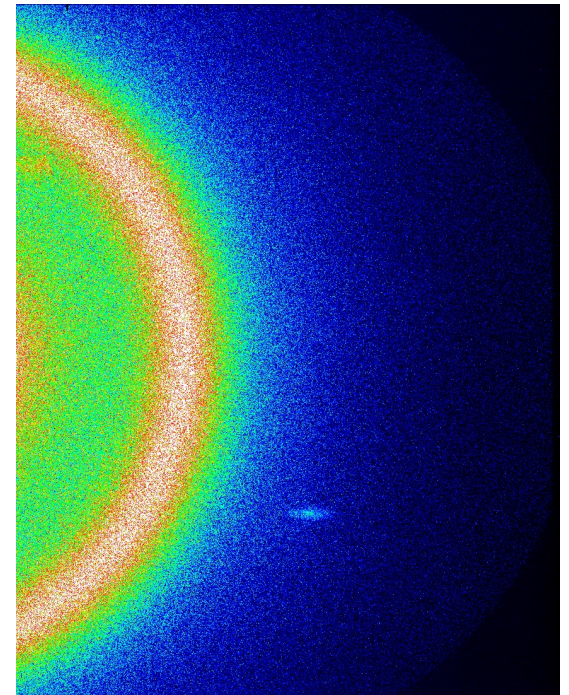

T=-34.7

Temperature Variation of Peak Position

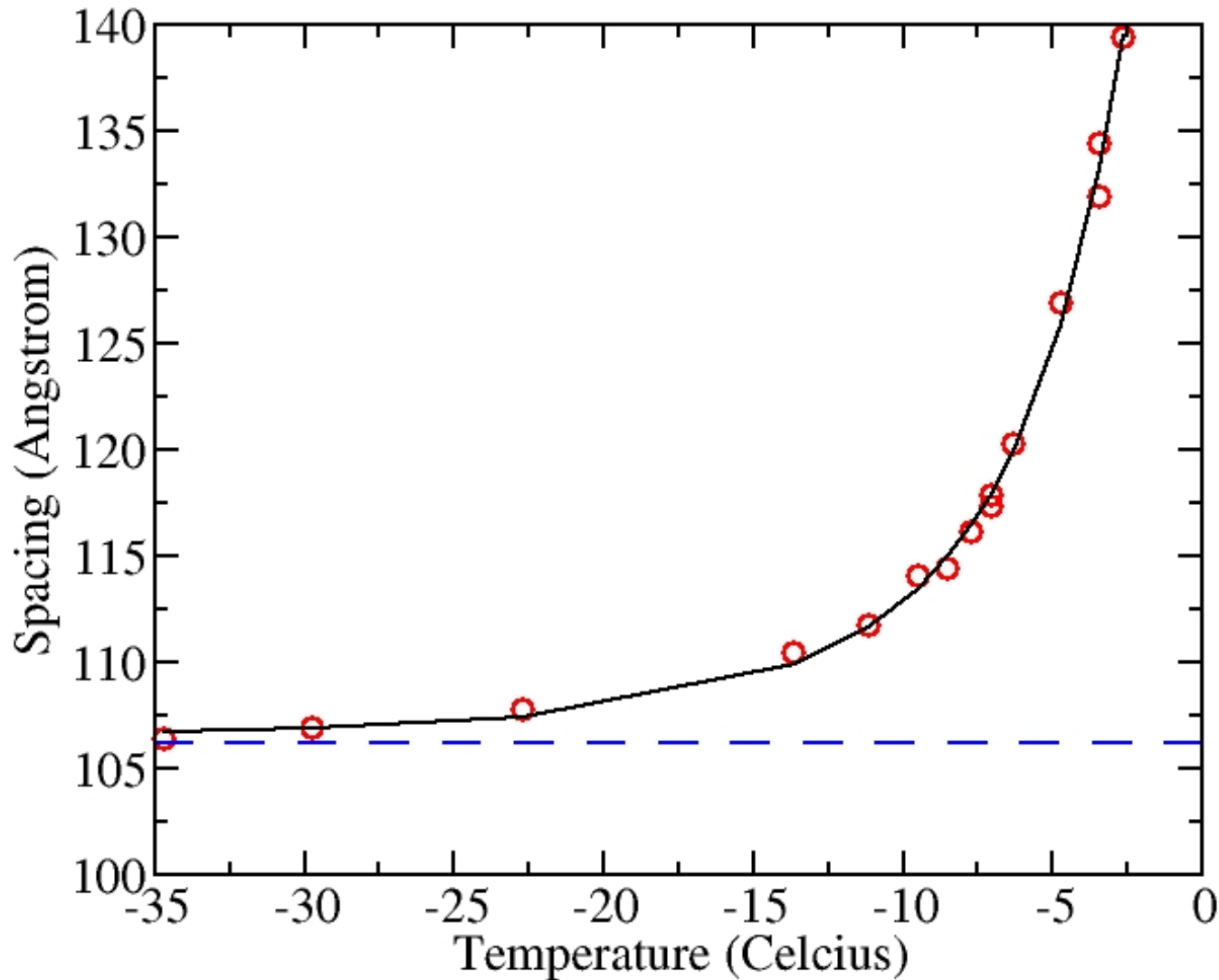

Structure Factors of Apoferritin

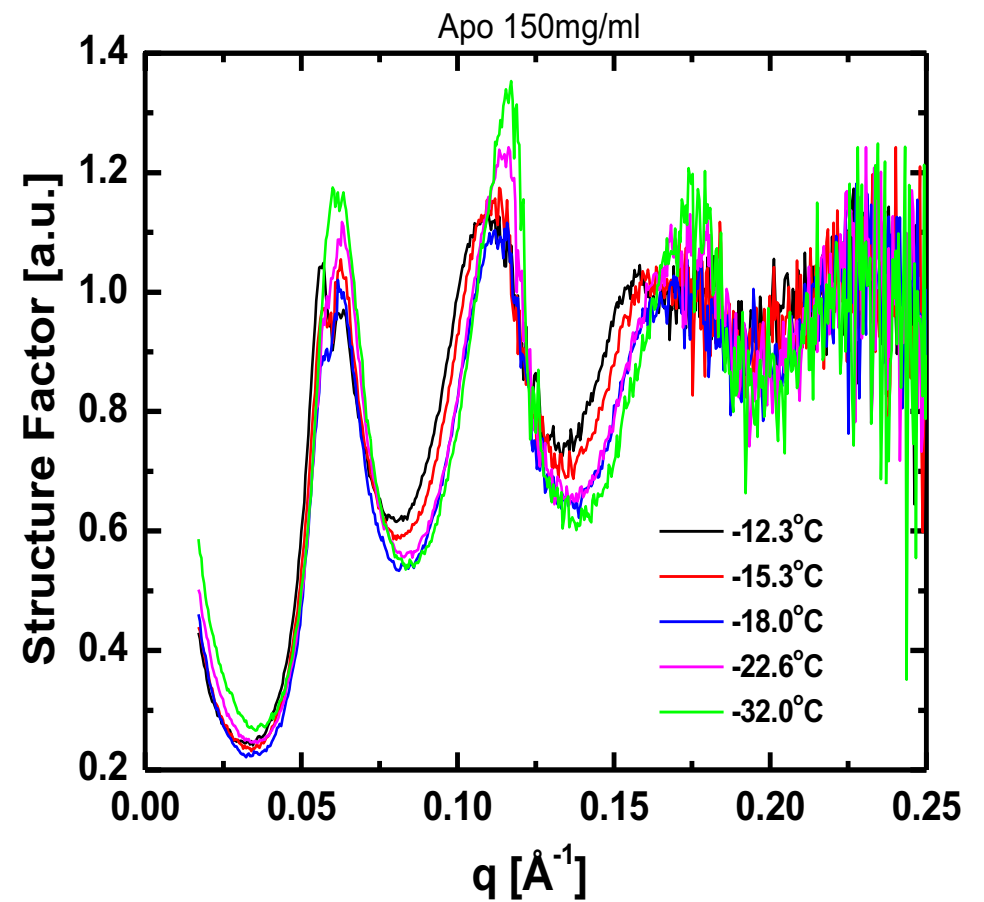
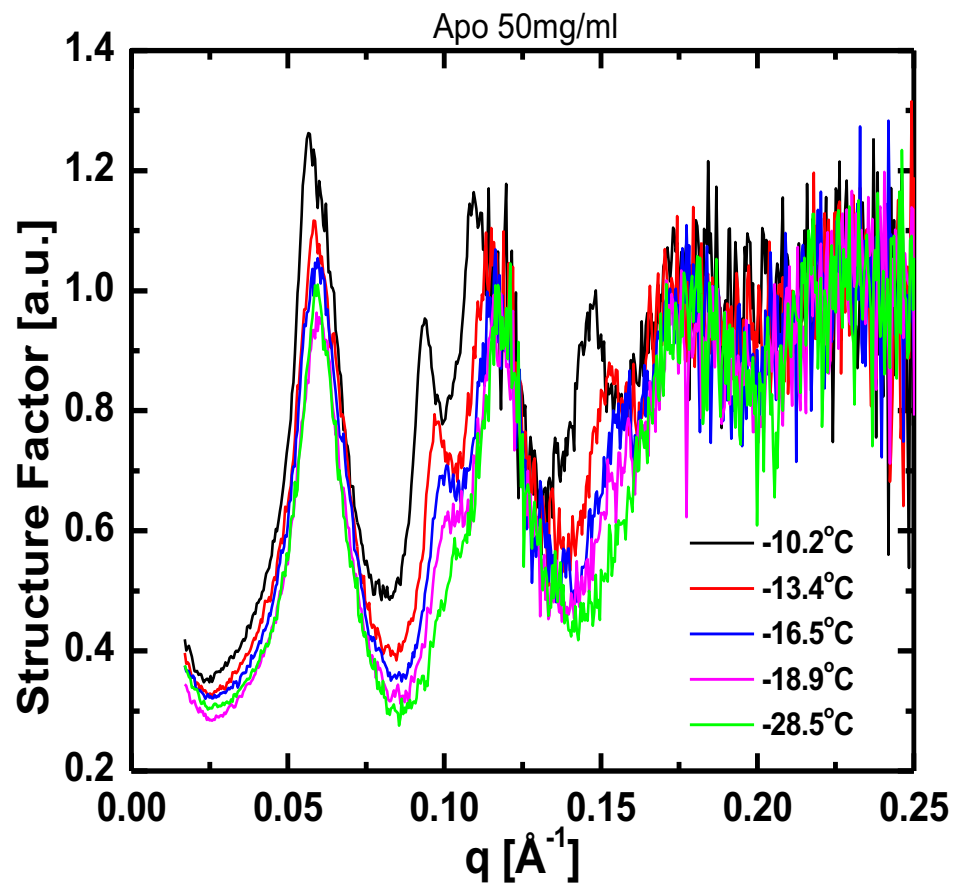

FCC Spherical Clusters

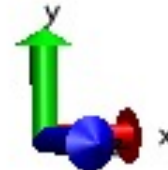
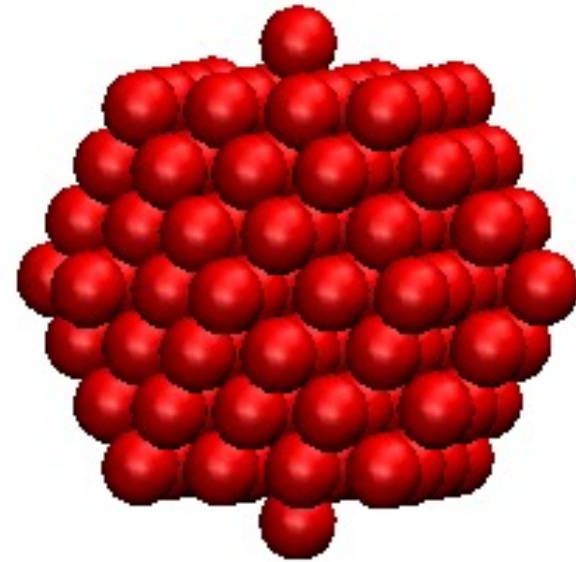
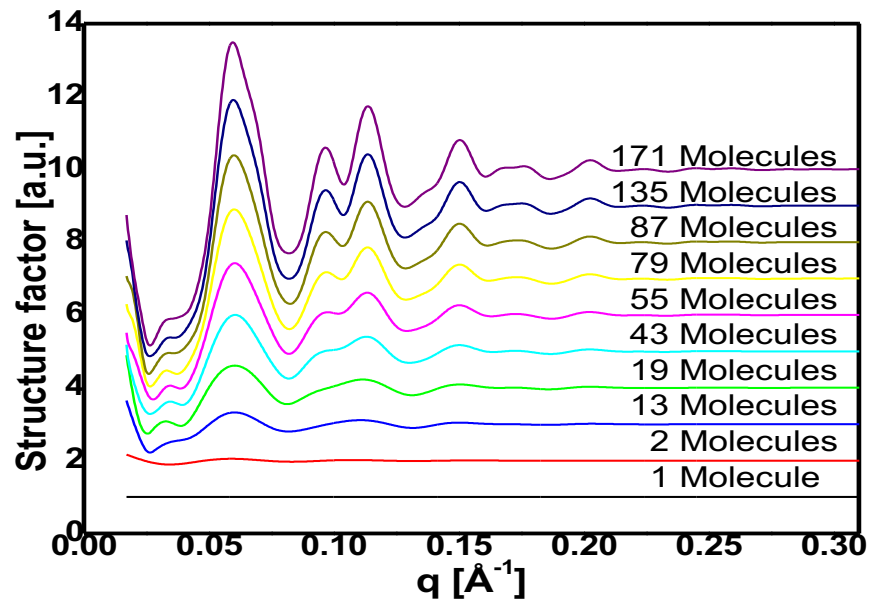

Planar Clusters of 110 Rods

Structure factor simulation as 5 $\langle 110 \rangle$ rods with
1 to 12 molecules per rod

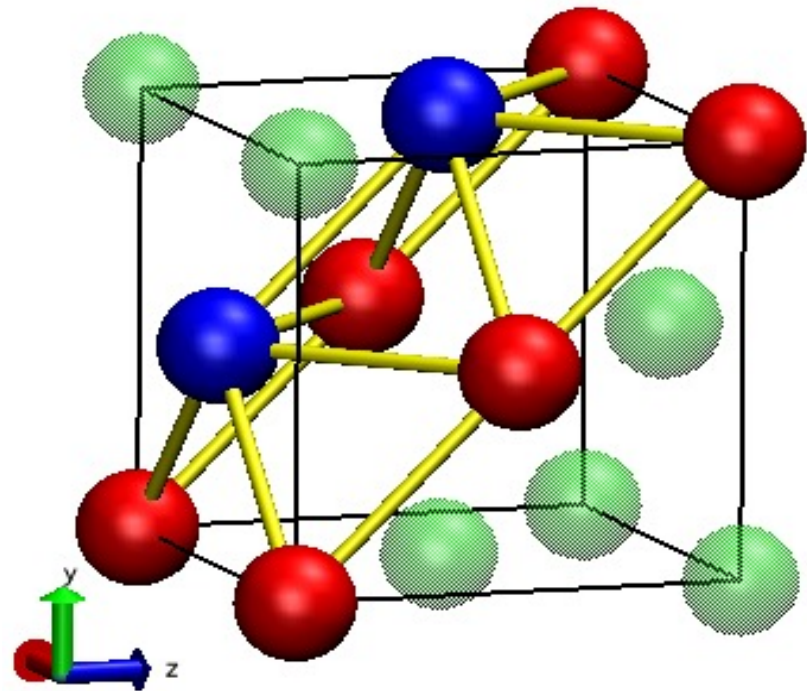
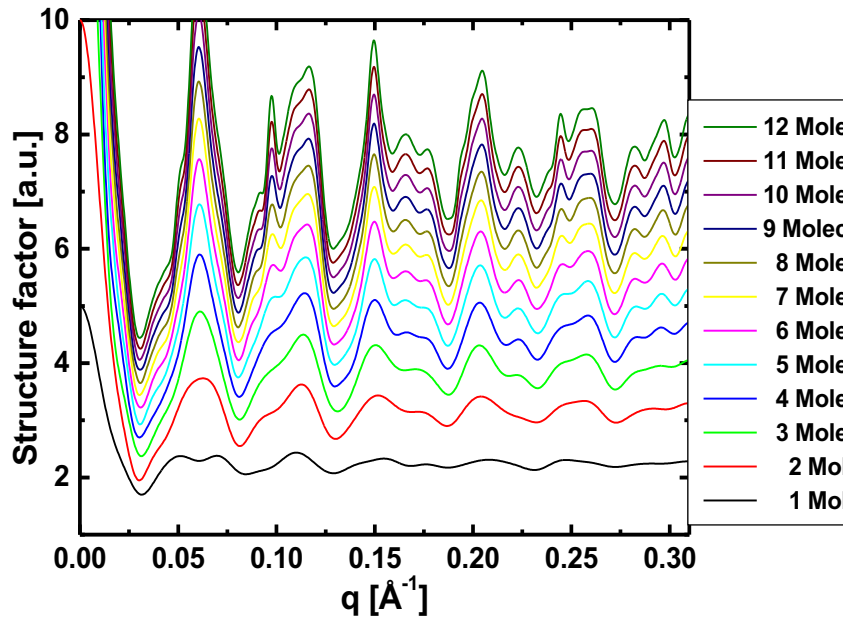

Best Fits

$T = -10^{\circ}\text{C}$

Cluster Size = 36

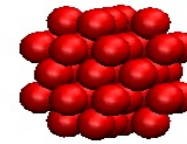
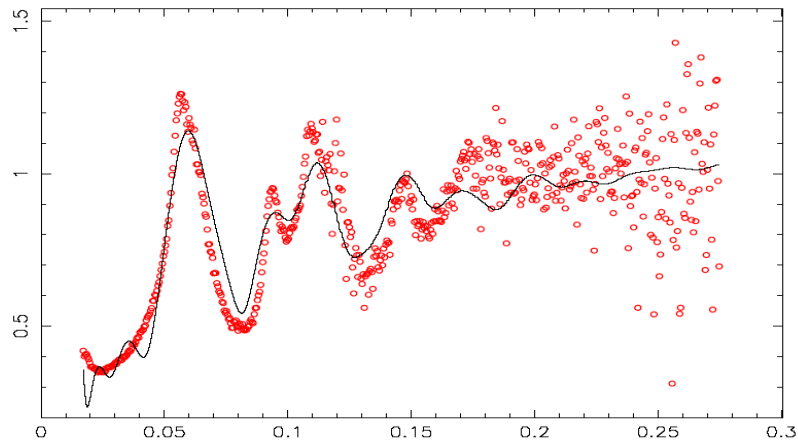

$T = -13^{\circ}\text{C}$

Cluster Size = 63

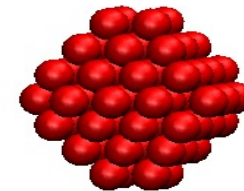
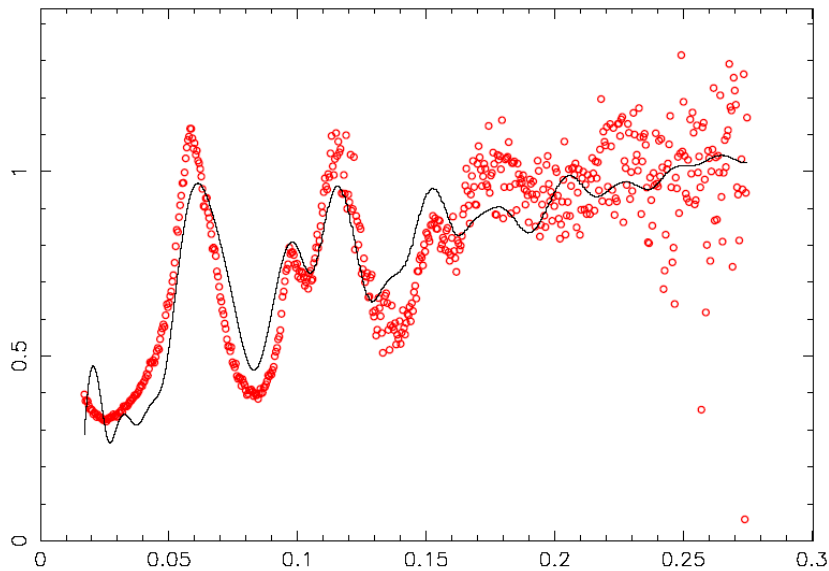

Ferritin (111) Powder Ring

- 50 frames
- 30sec exposure
- 0.3sec playback
- 150x200 pixels of 22.5 μm

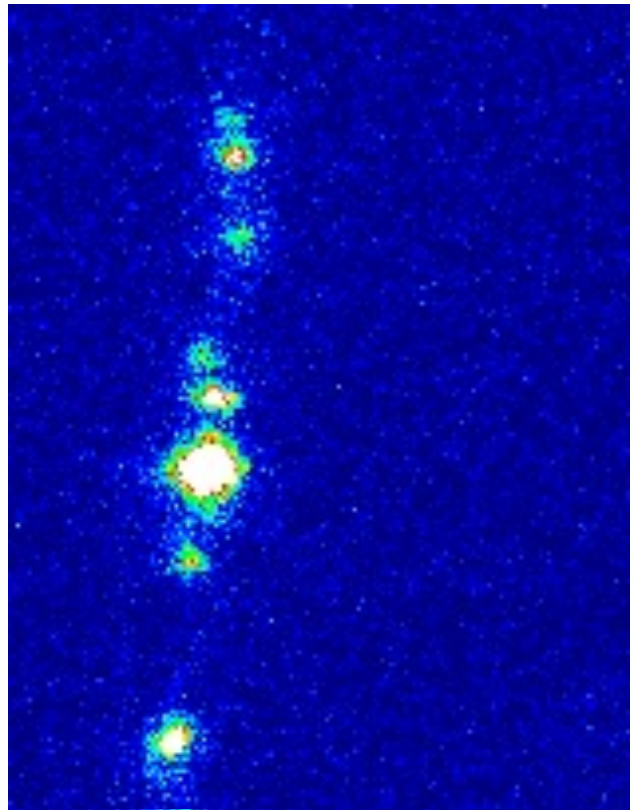

Overview of EM grid

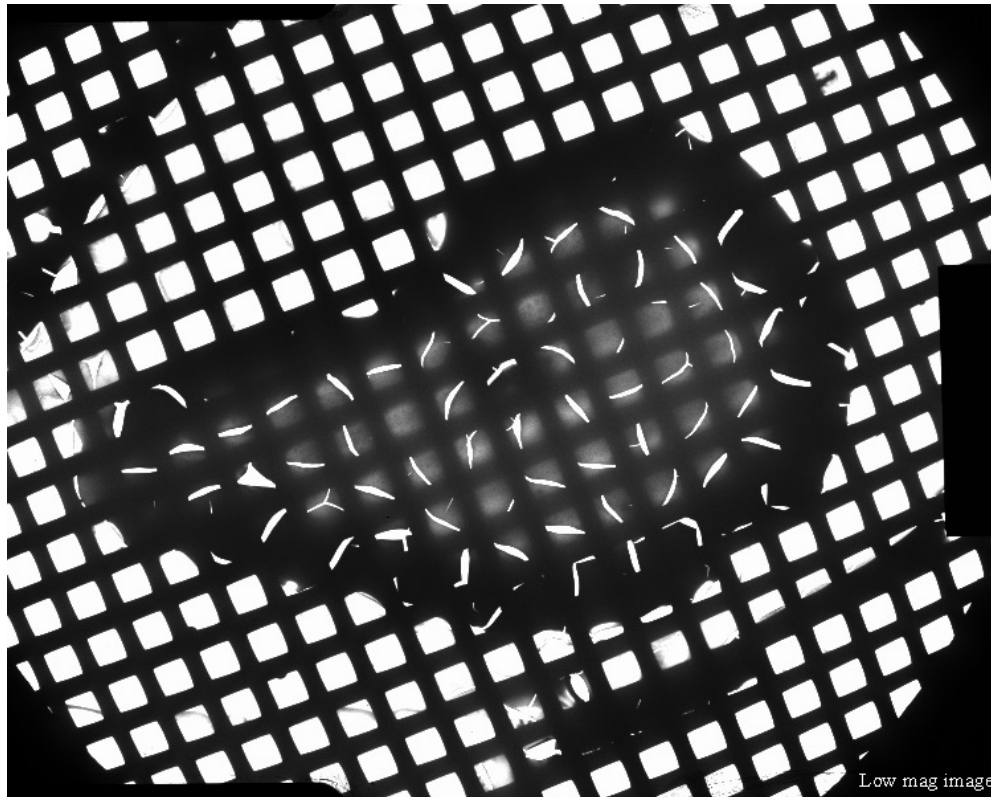

- 3mm diam grid
- a-carbon + “Formvar”
- 10mg/ml Ferritin
- 10mg/ml NaCl
- dipped grid
- dried in air
- no cryo-cooling
 - ▷ three regions of different density

Border Region (low density)

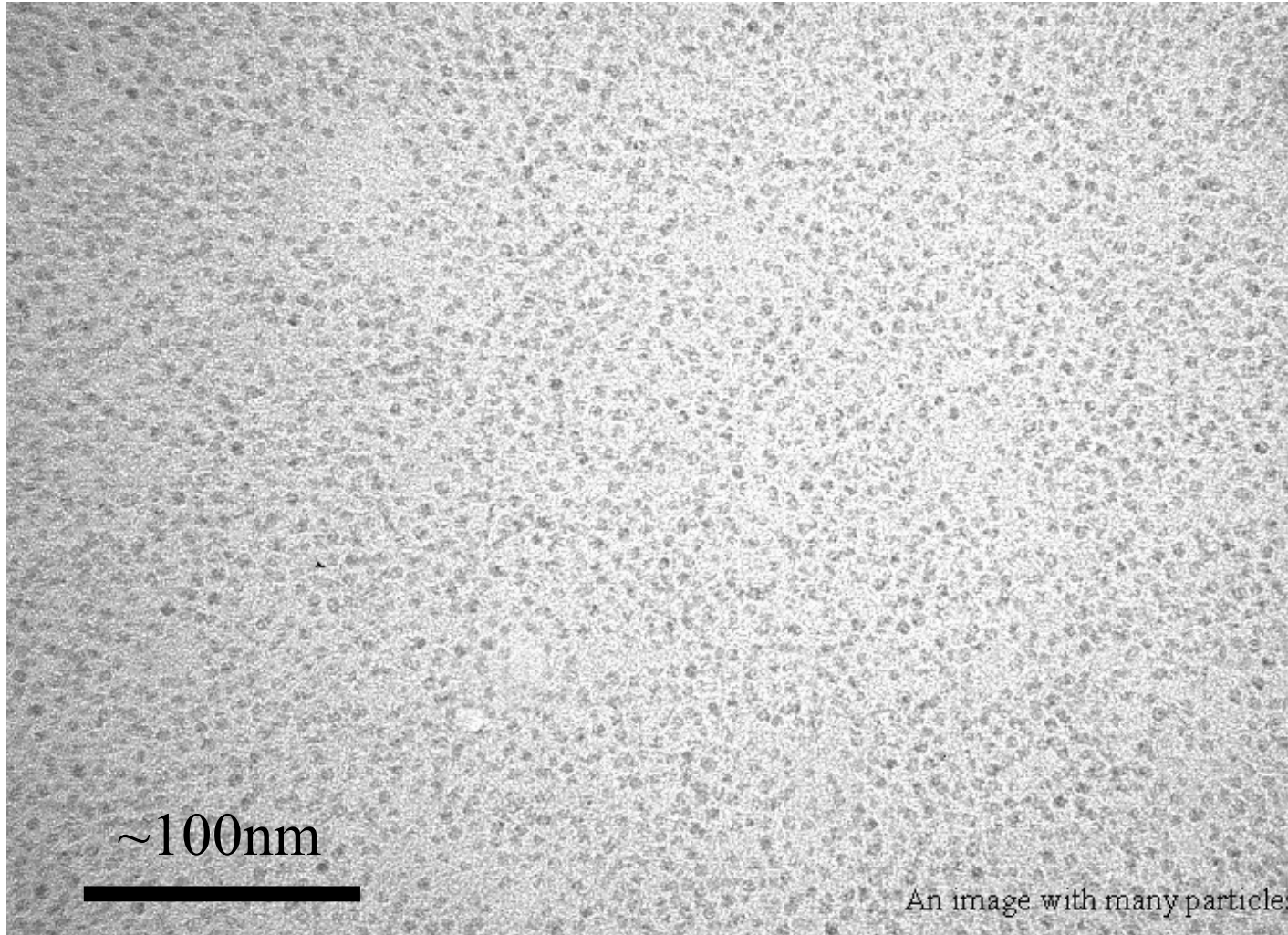

I. K. Robinson Astbury 2007

High Density Ring

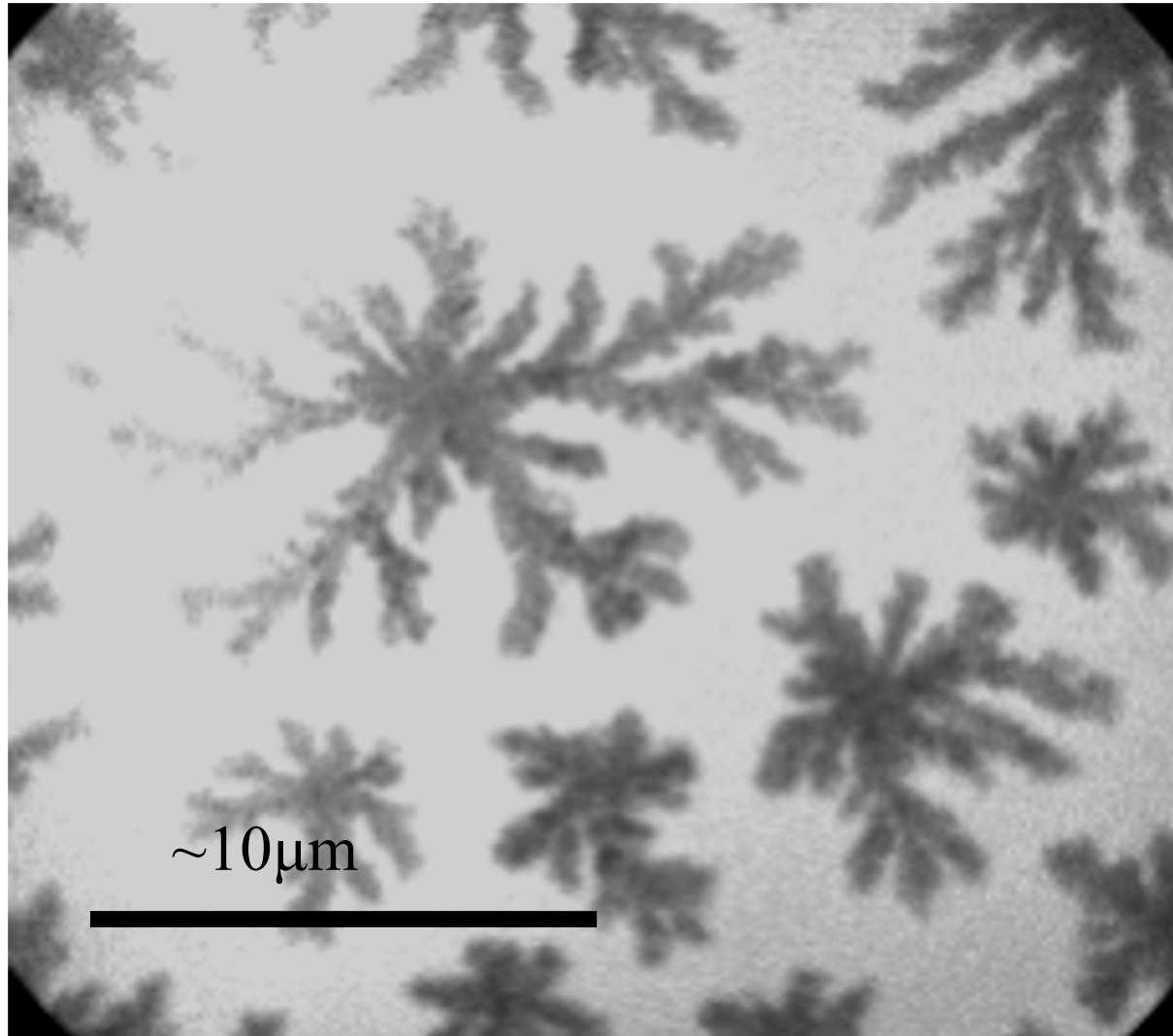

I. K. Robinson Astbury 2007

Diffraction from Border Region

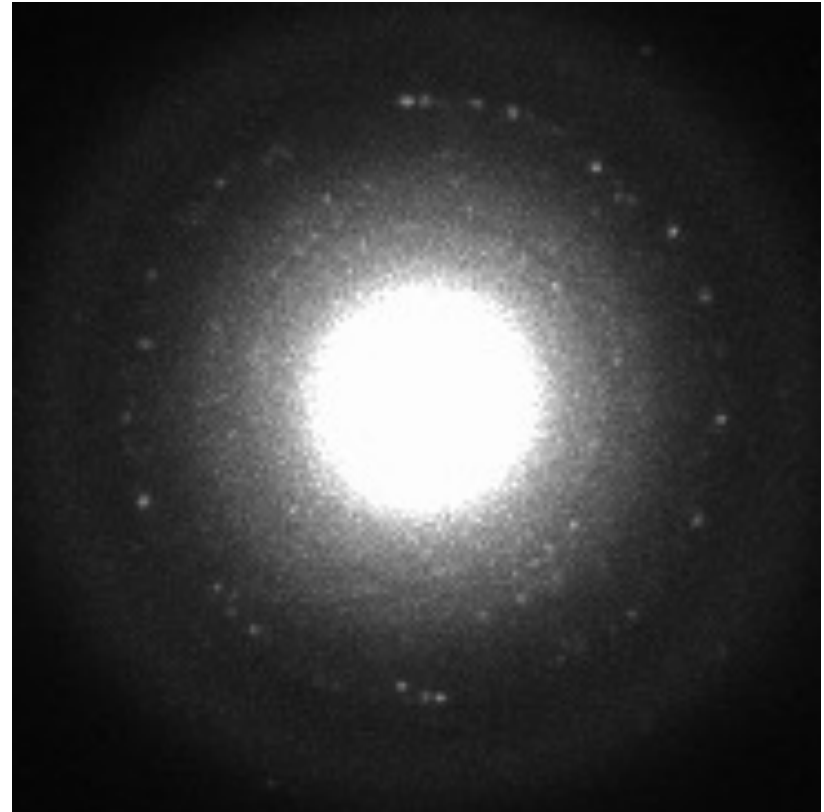
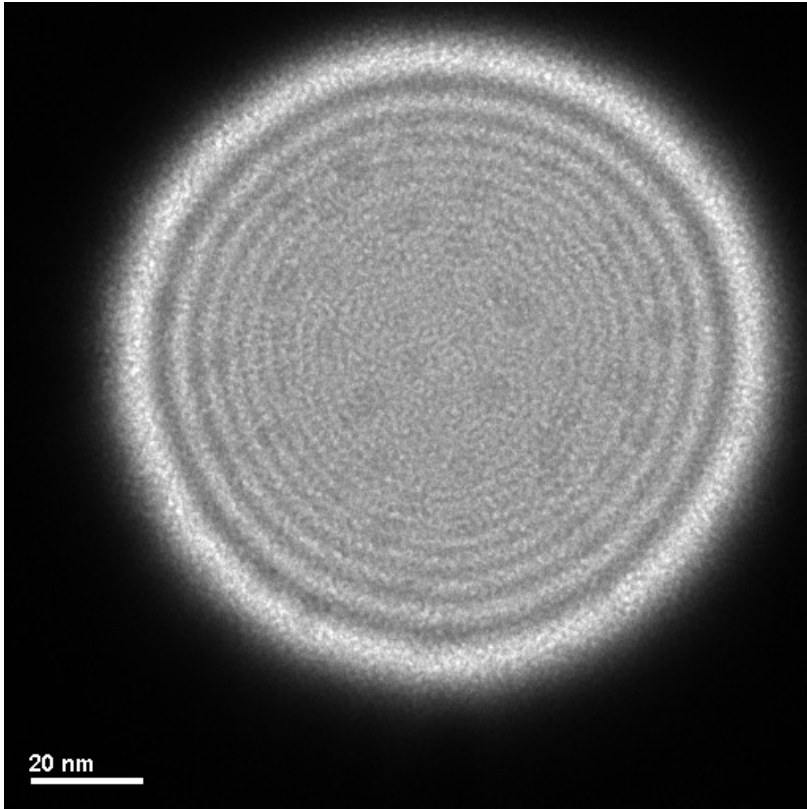

Lensless X-ray Microscope

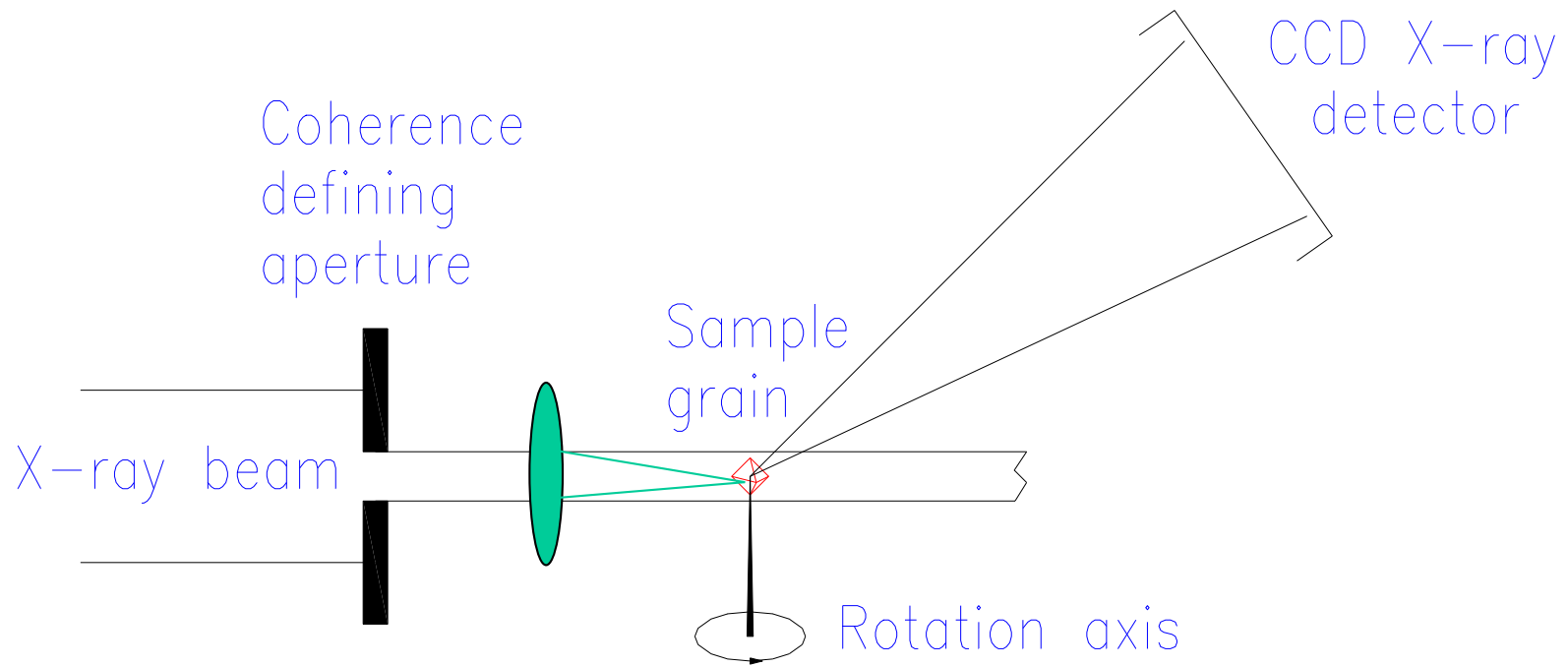

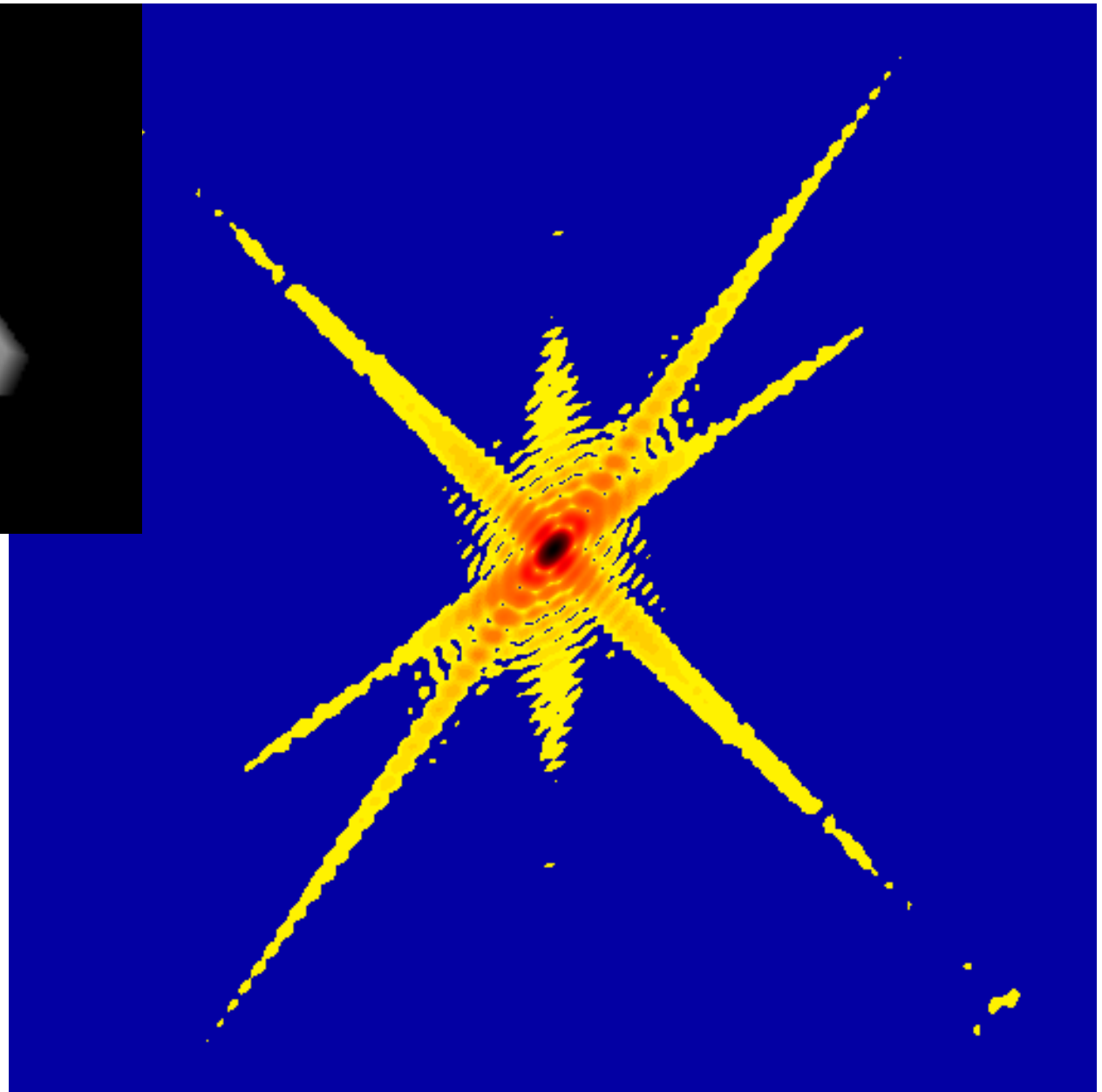
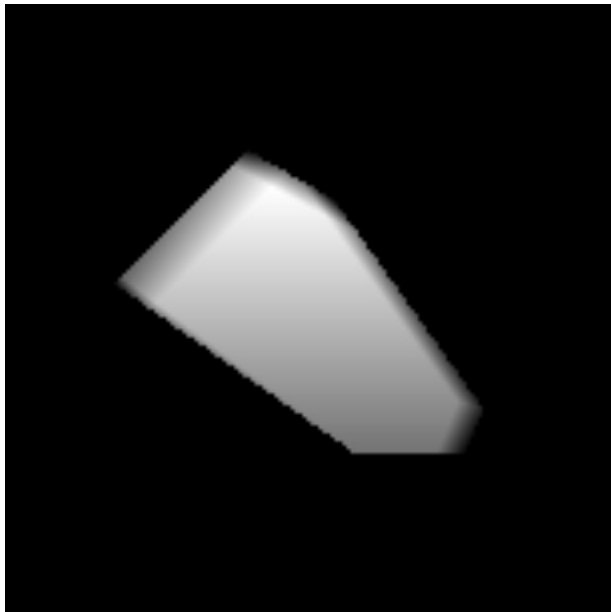

I. K. Robinson Astbury 2007

Coherent Diffraction from Crystals

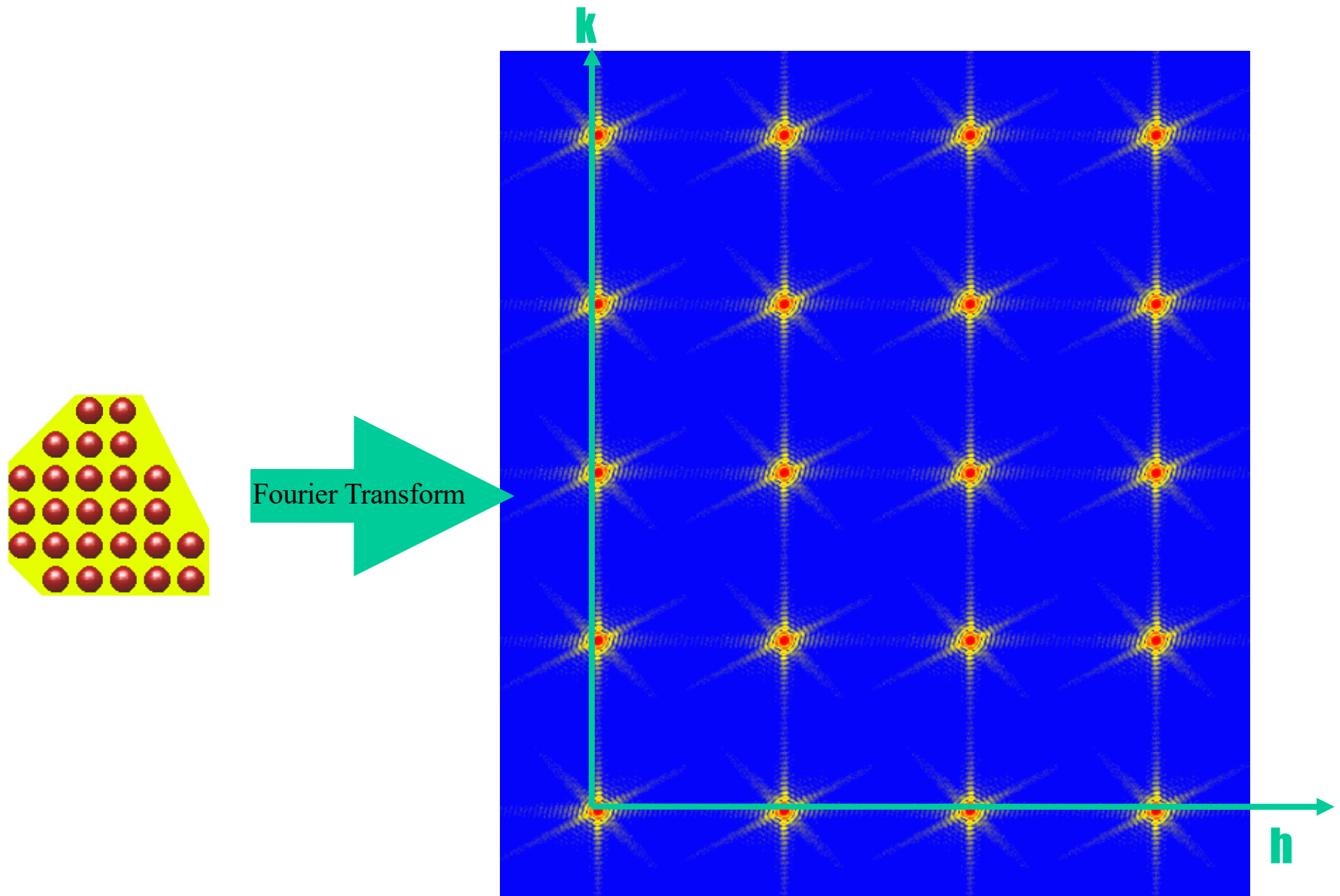

3D Diffraction Method

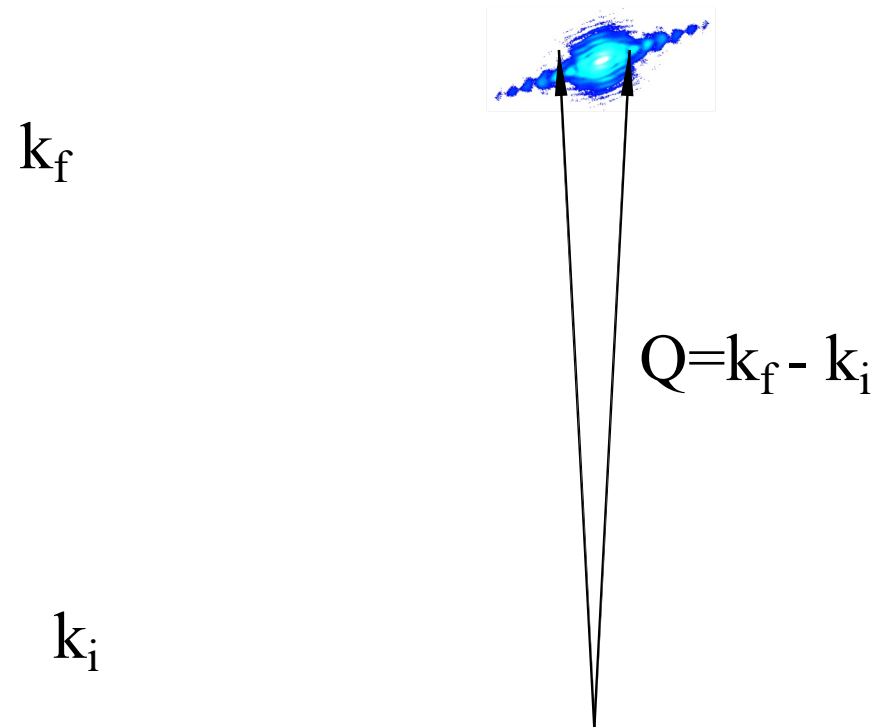

Chemical Synthesis of Nanocrystals

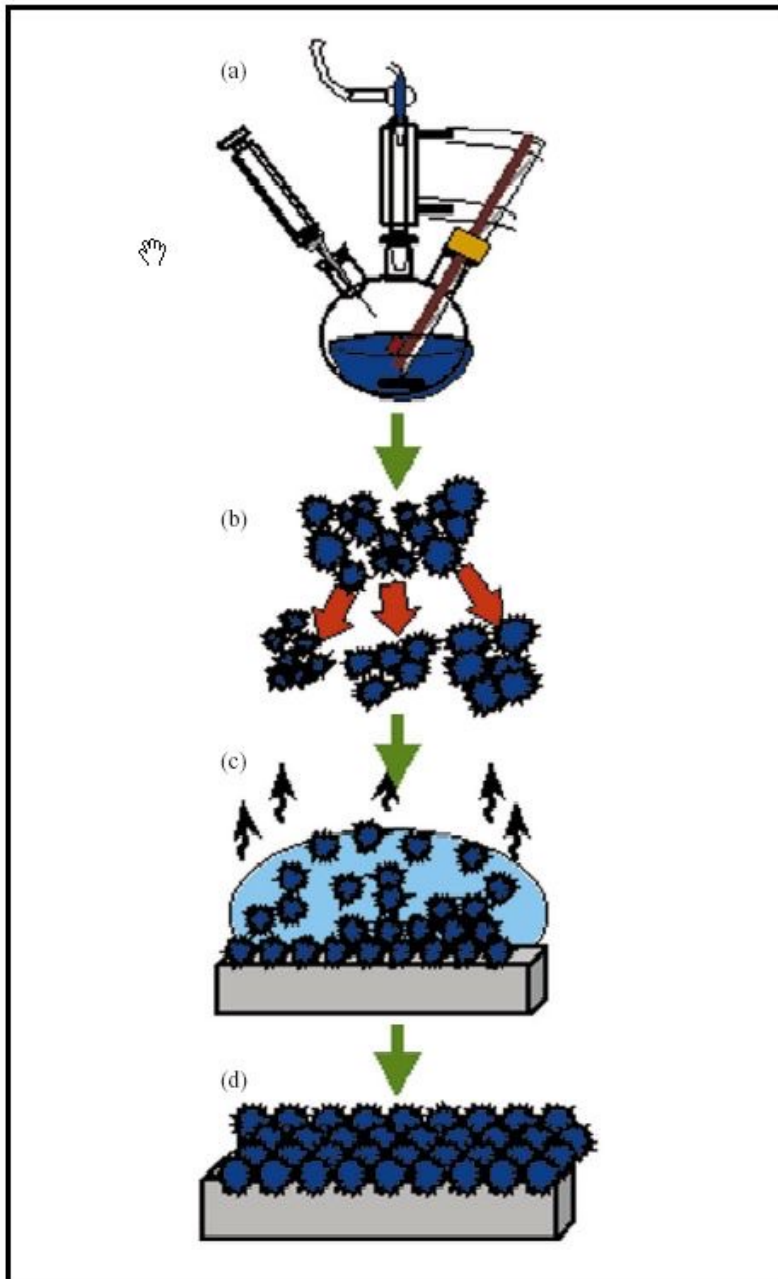

- Reactants introduced rapidly
- High temperature solvent
- Surfactant/organic capping agent
- Square superlattice (200nm scale)

C. B. Murray, IBM J. Res. & Dev. **45**
47 (2001)

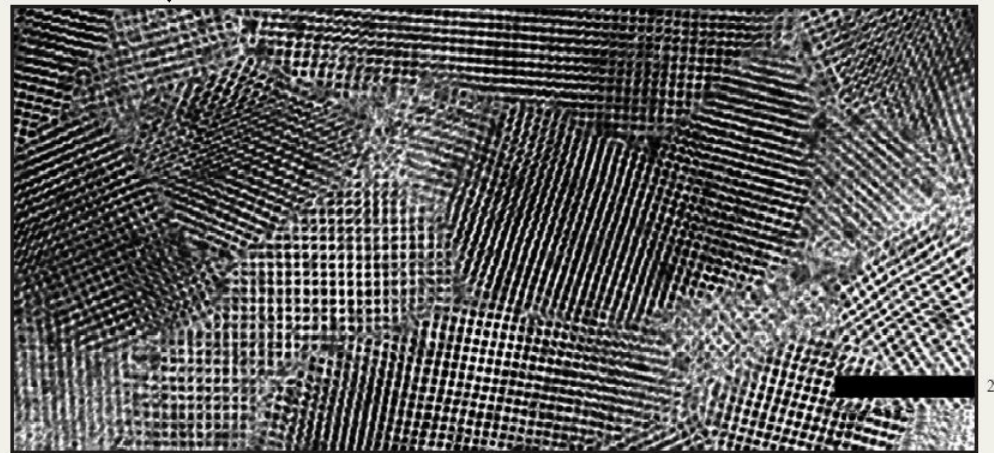

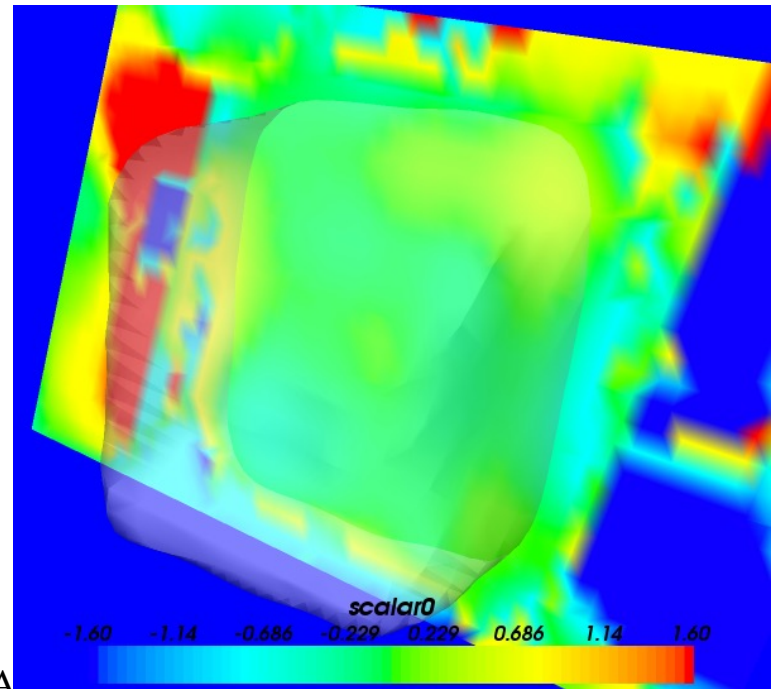
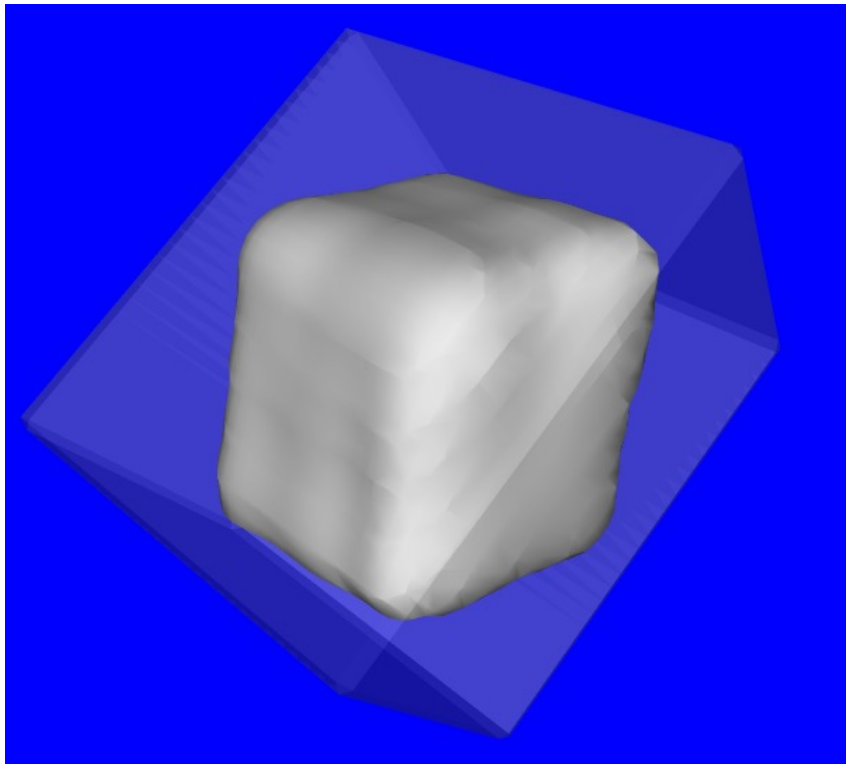
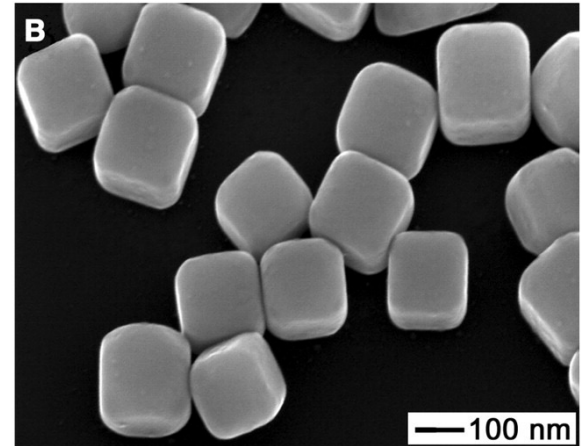
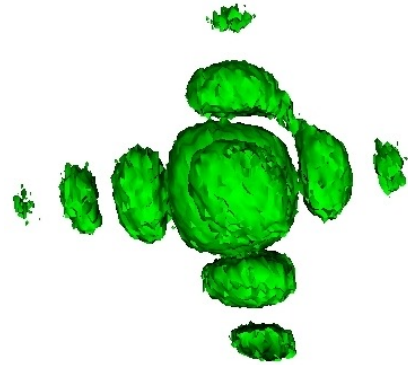
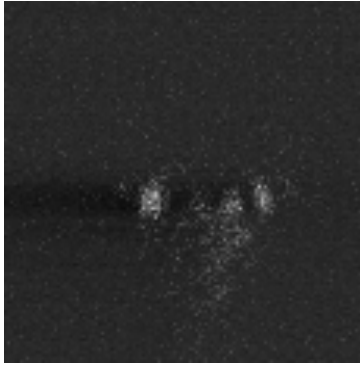

In situ growth of Pb crystals

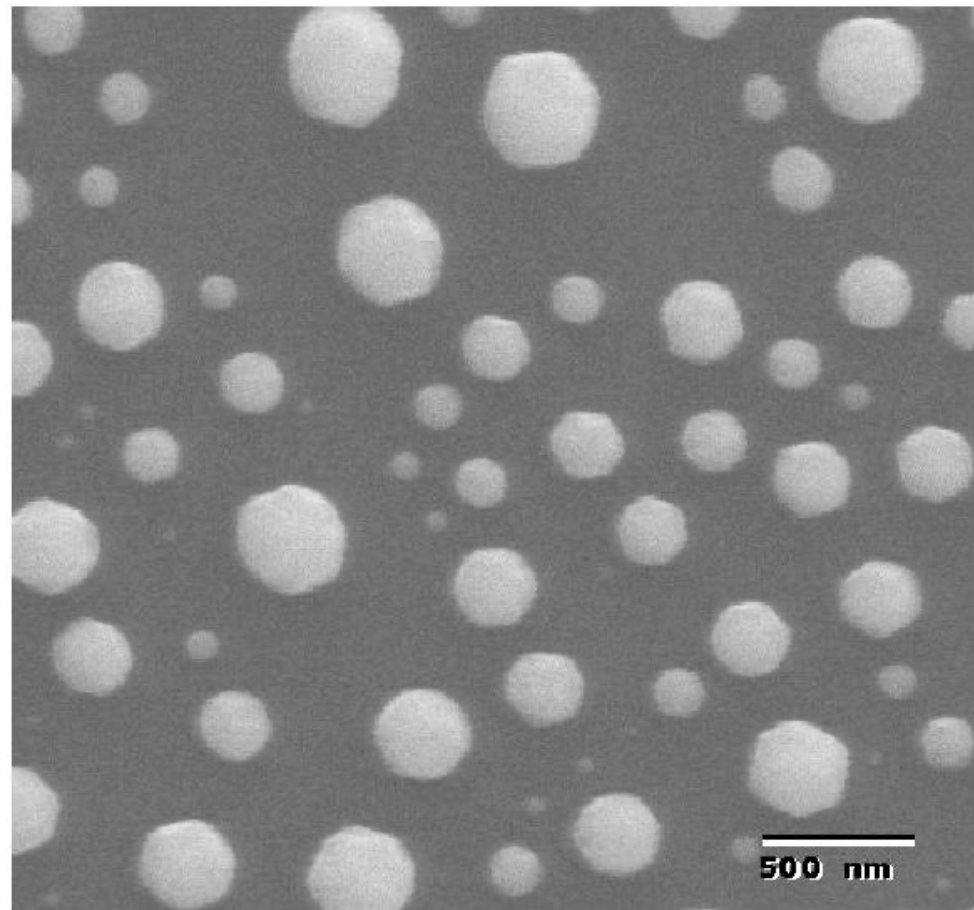
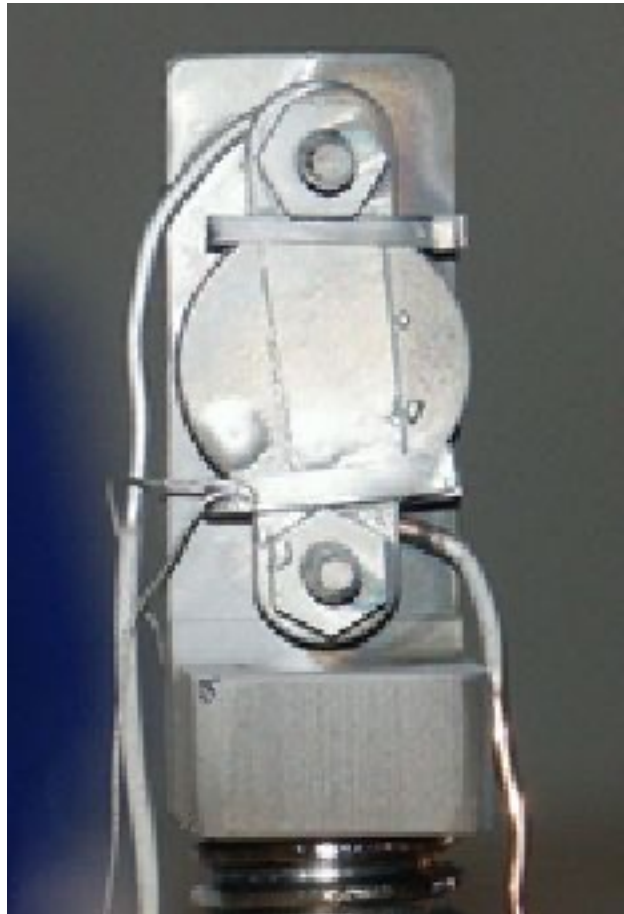

Good statistics, 3D diffraction data

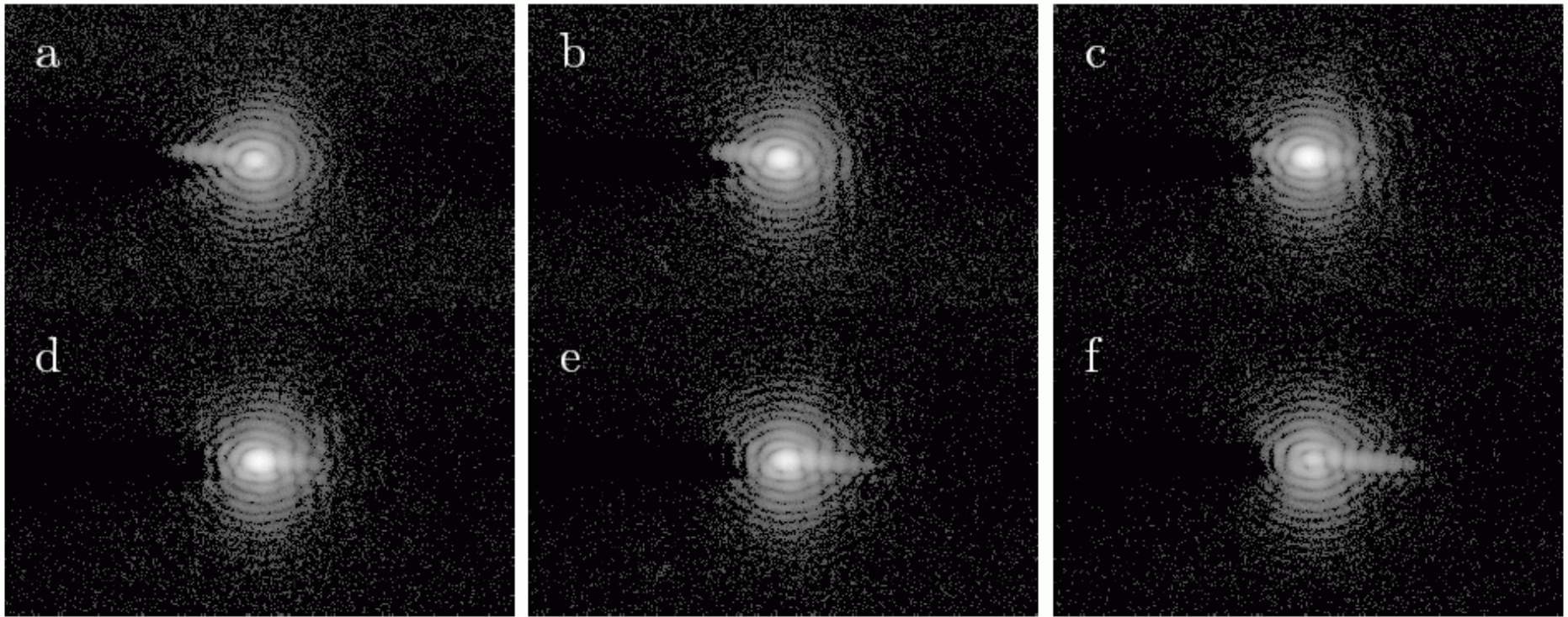

Figure 4.12: Center slices from 3D CXD pattern from Pb sample, on a log scale. Data file 296 from 10/03.

Facets of Equilibrium Crystal Shape



I. K. Robinson Astbury 2007

3D phase map sections

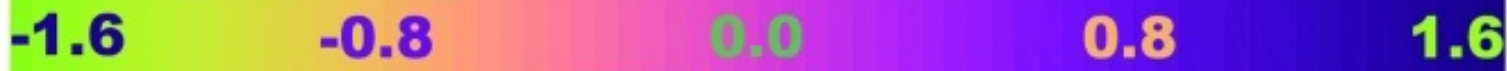
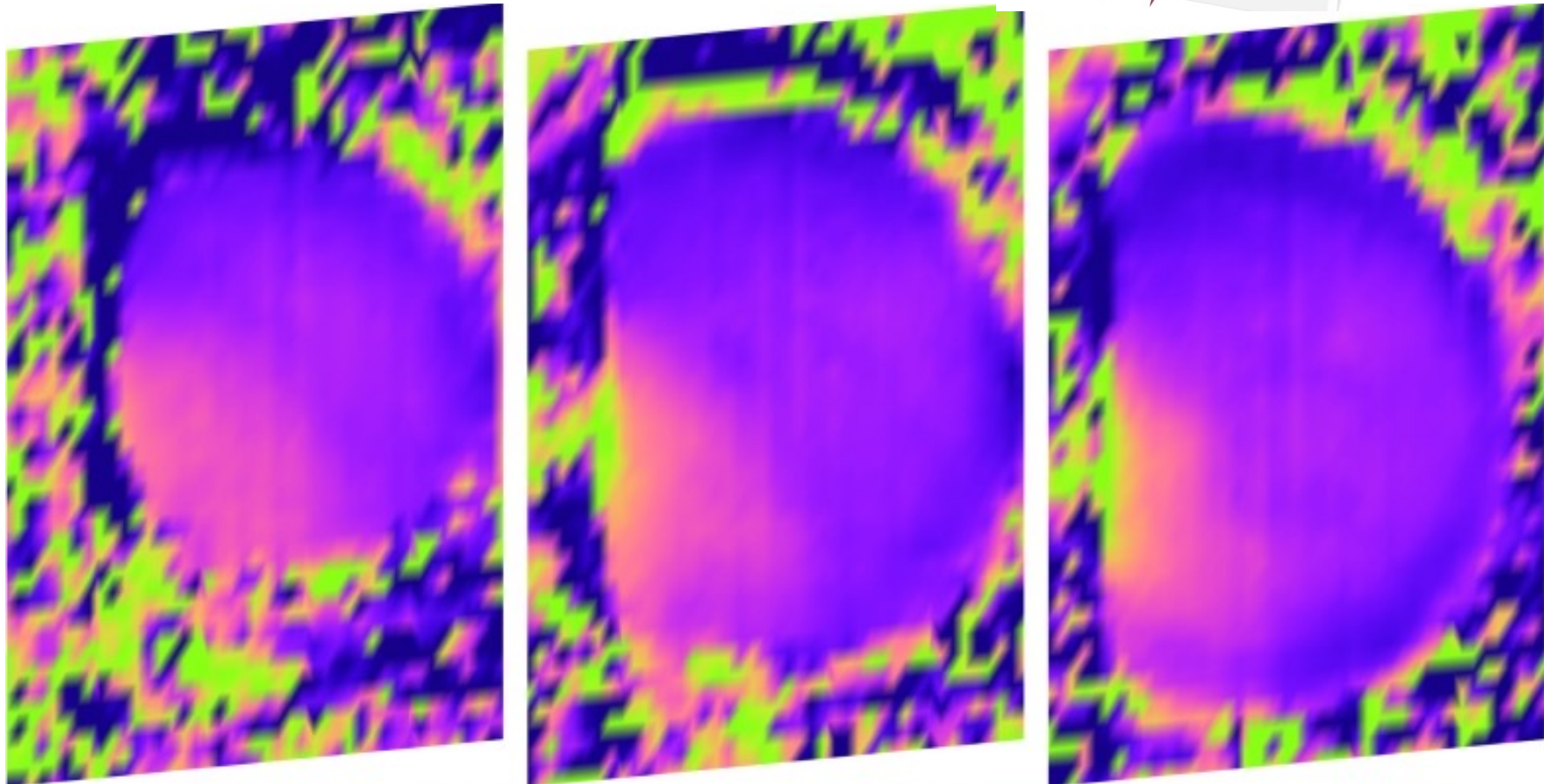
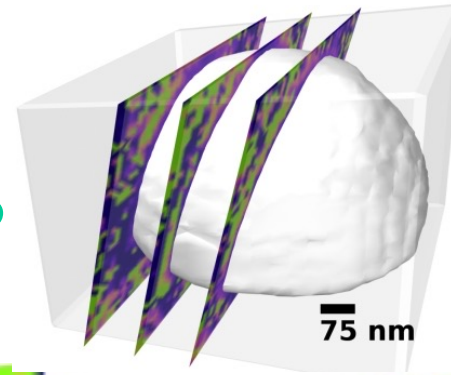

Modeling of 3D Phase Bump

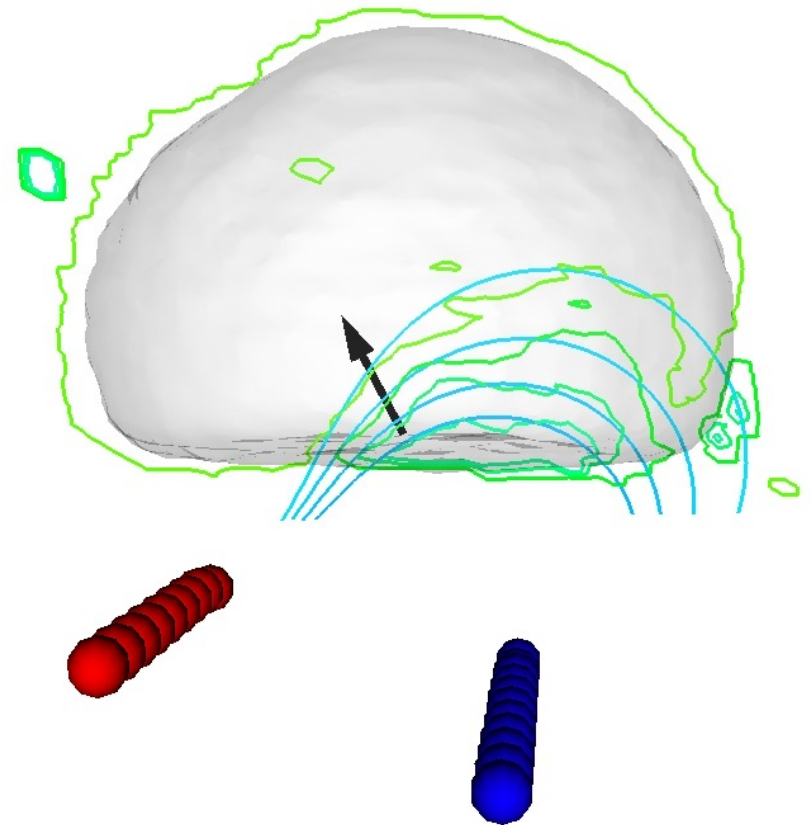
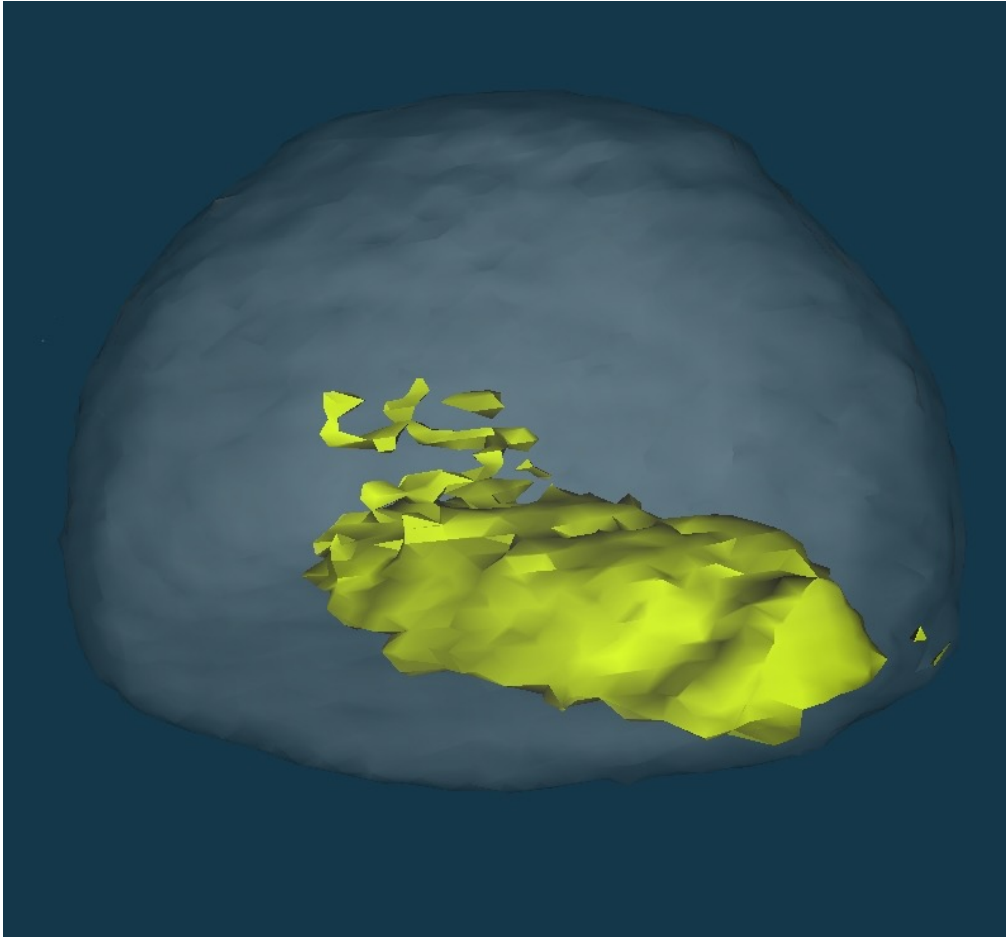

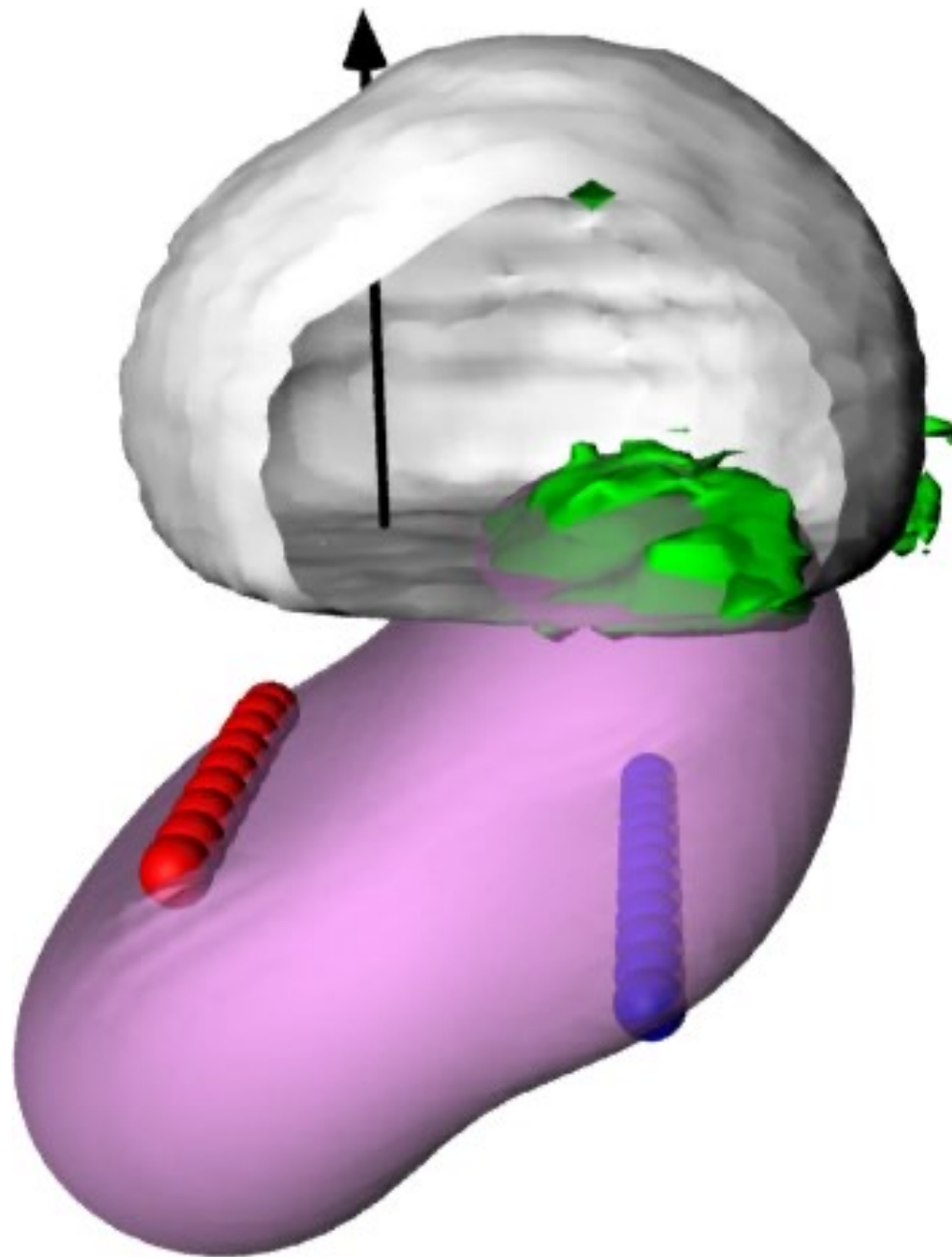

I. K. Robinson Astbury 2007

Refraction effects in Lead at 8.9keV

Phase accumulation due to refraction along scattering path
 $d=750\text{nm}$: $kd\delta = 0.76\text{rad}$
 $kd\beta = 0.07$

$$\delta = 2.23 \times 10^{-5}$$
$$\beta = 2.19 \times 10^{-6}$$

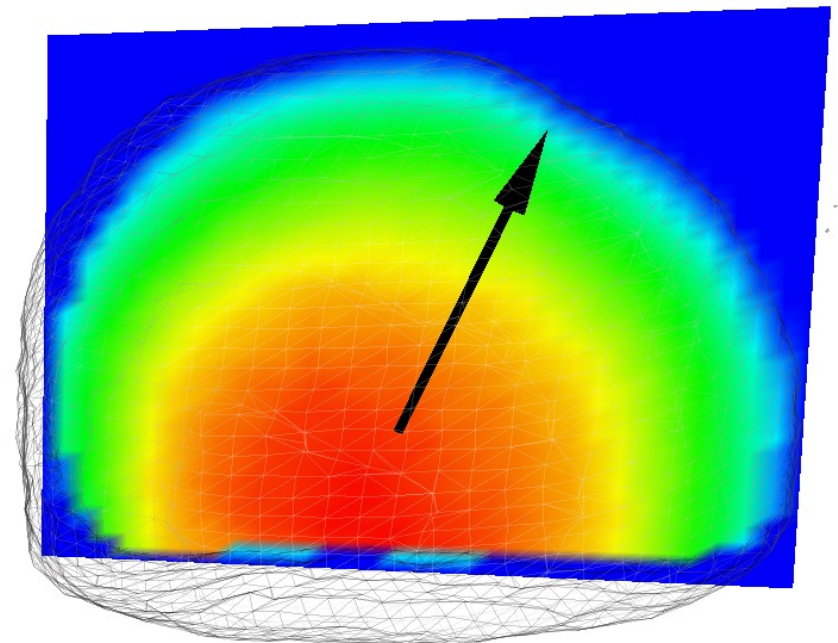
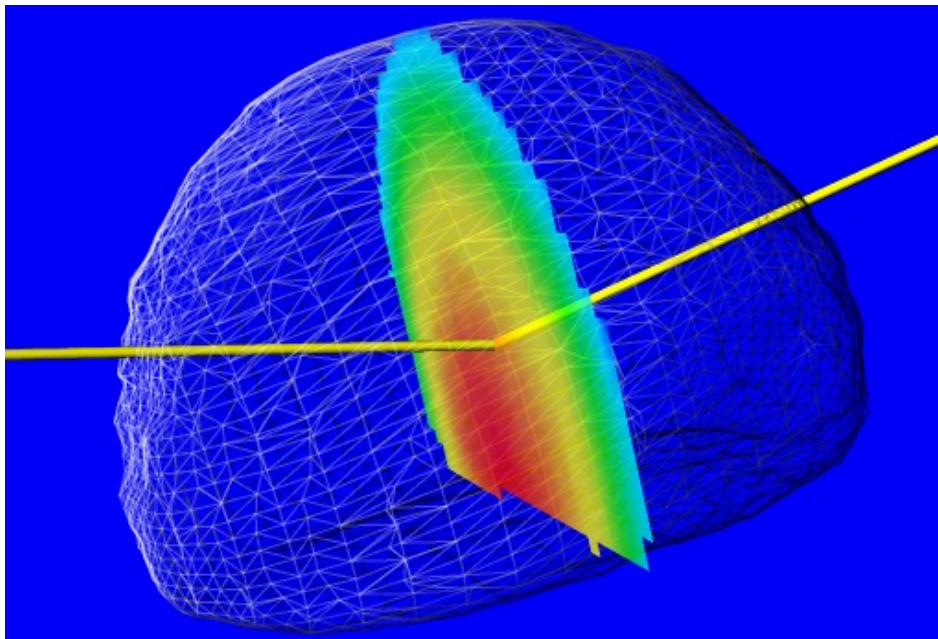

Phase Maps before and after Correction

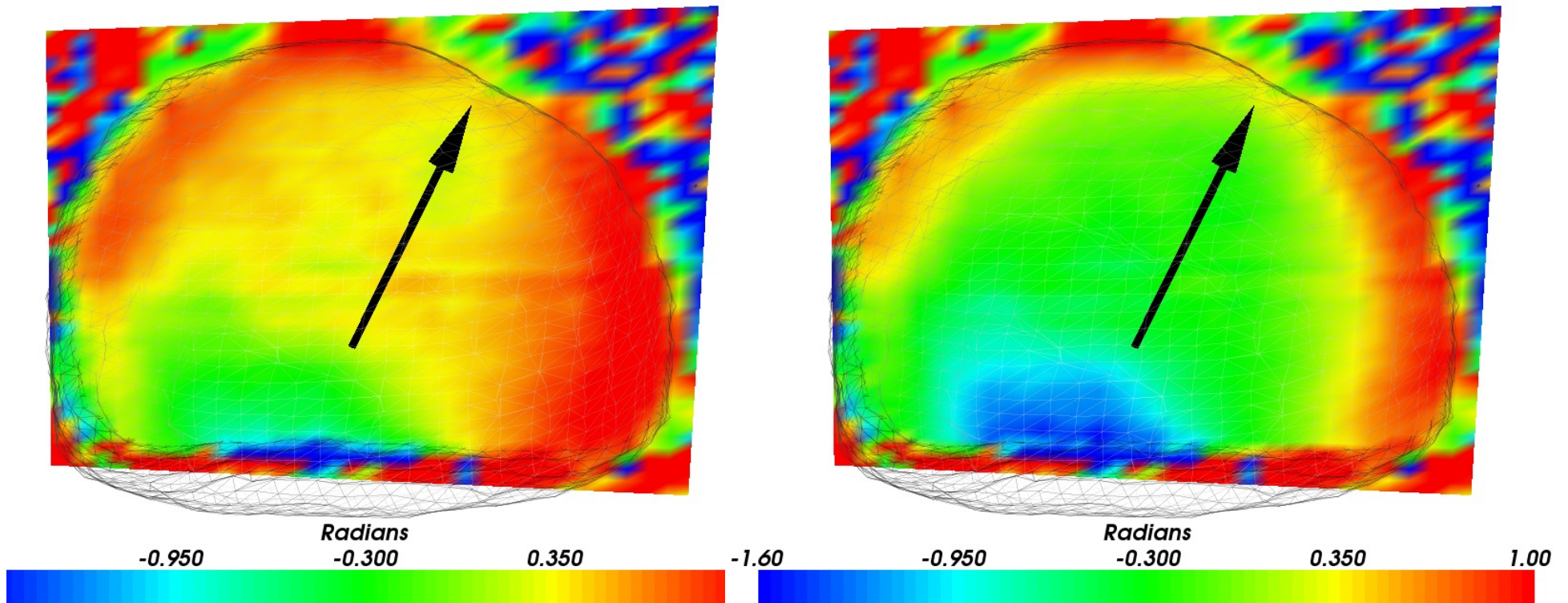

Positive Phase is Surface Expansion

including correction for refraction by crystal

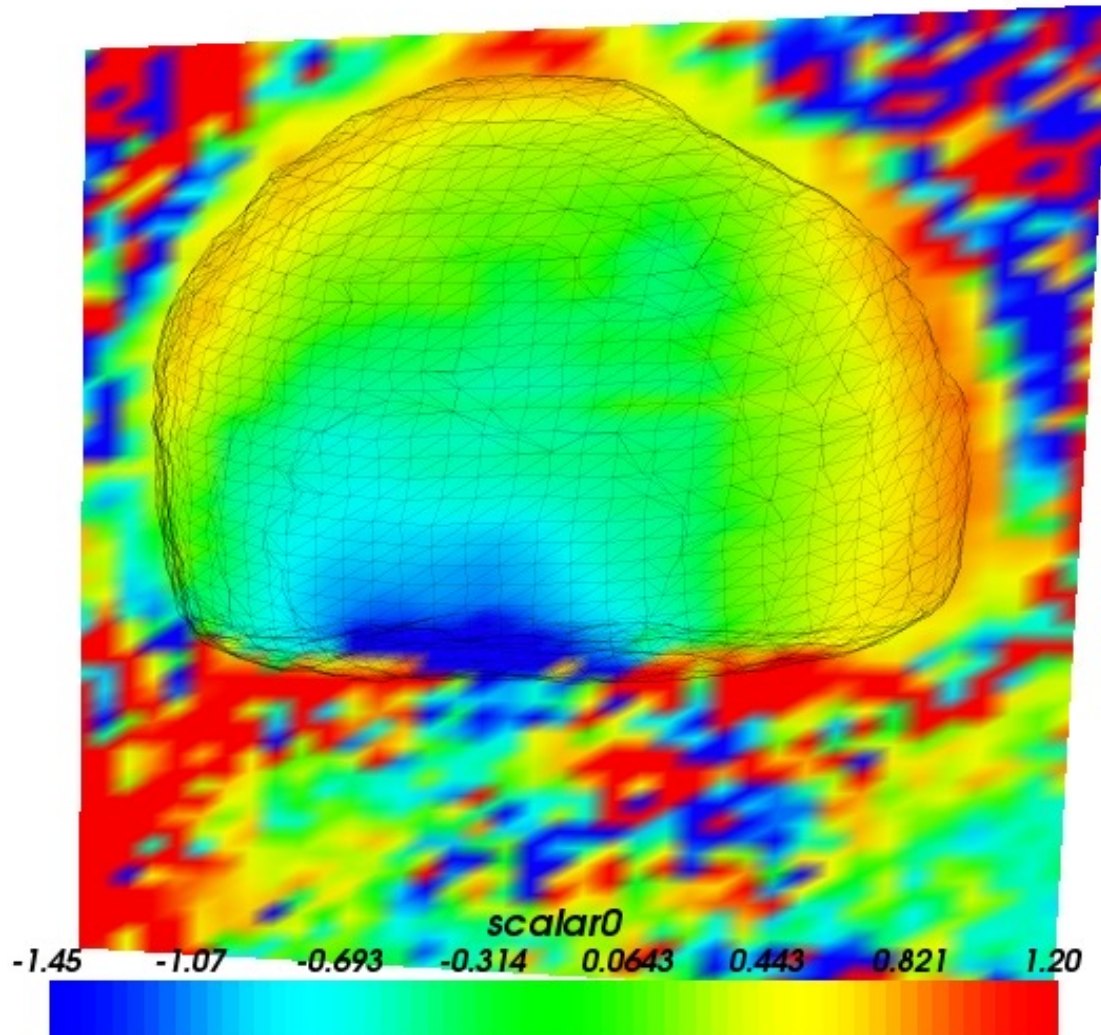

Max phase = 1.15rad
= 0.052nm

Phase on (111) facet:
= 0.47 rad
= 0.02nm

Depth Variation of Distortion

Facets subtend $18.6 \pm 2.6^\circ$
ECS predicts 14°

Depth measured $90 \pm 20\text{nm}$
Theory says 75nm

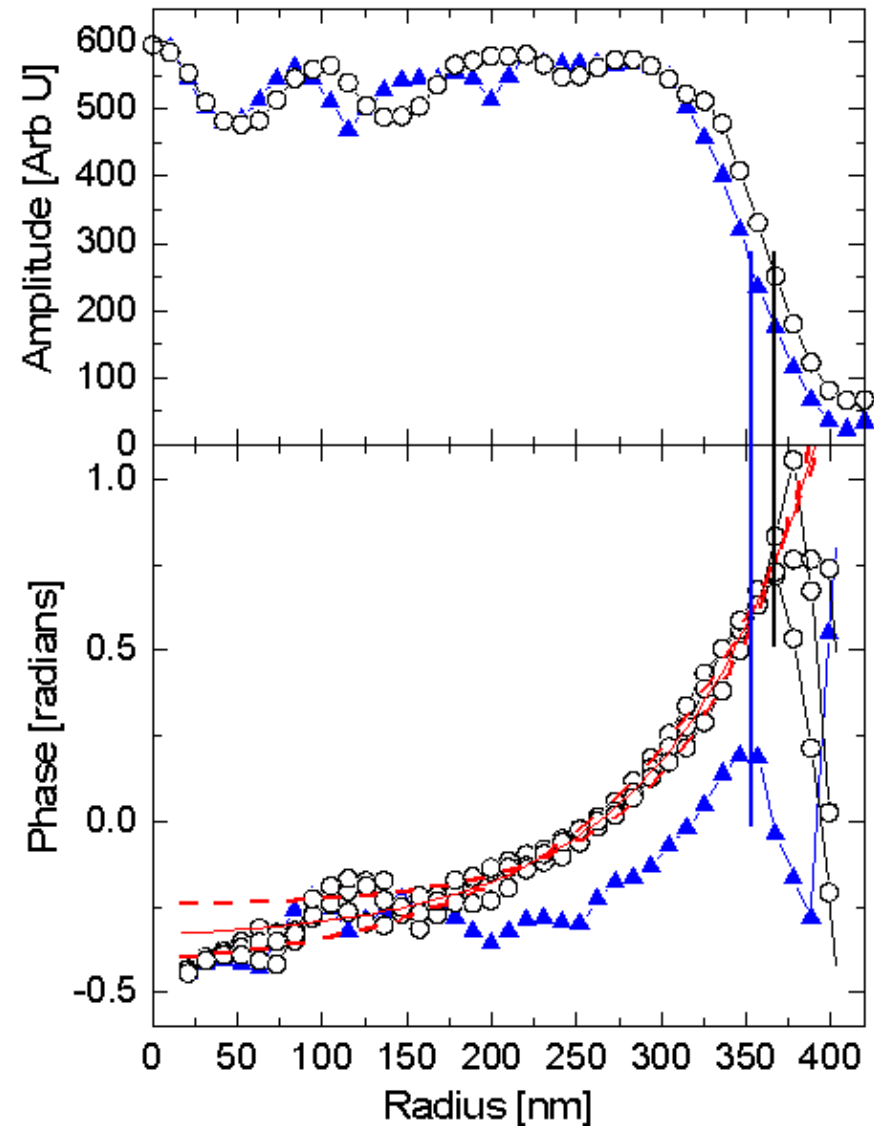
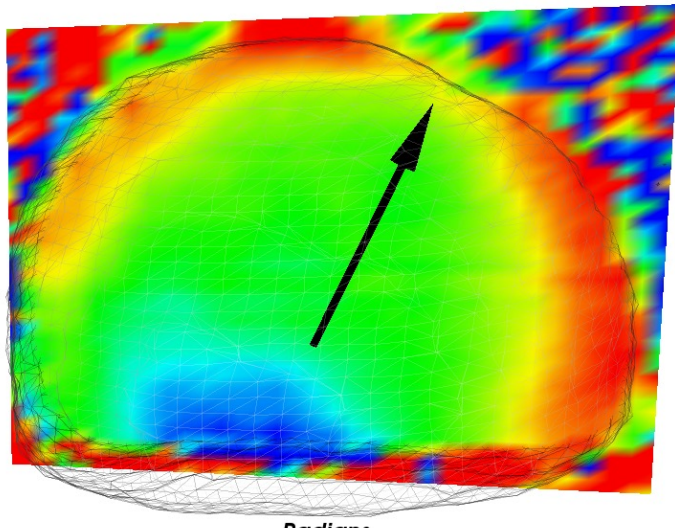

I. K. Robir

Molecular Movies using XFEL

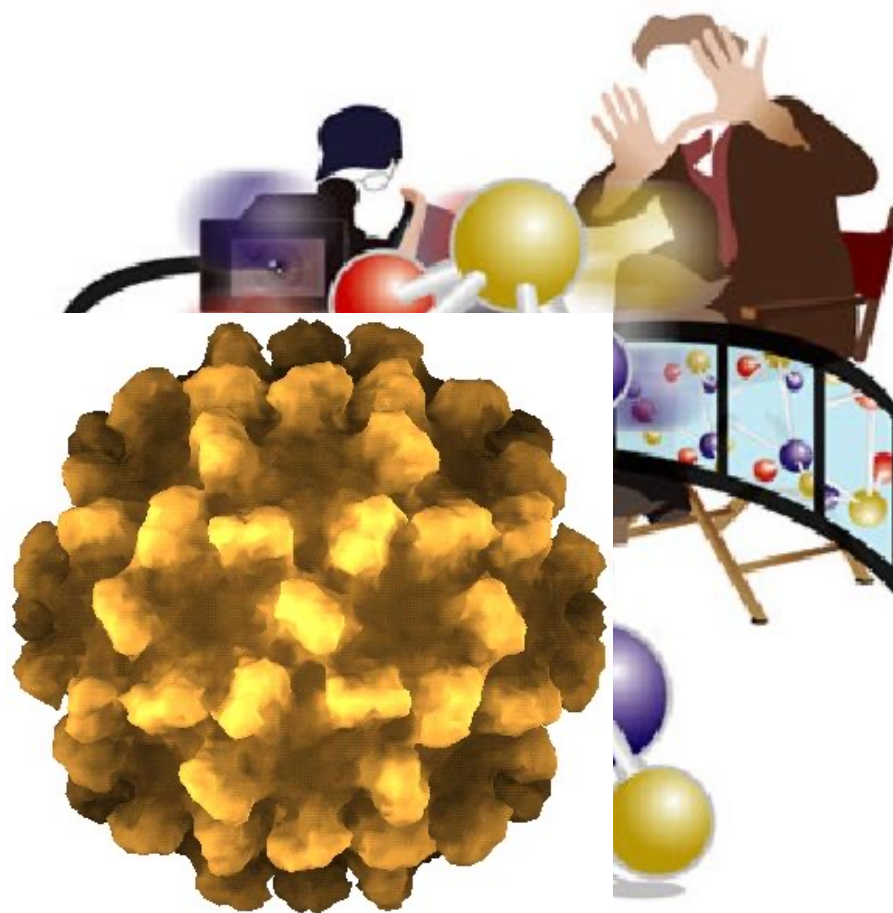

I. K. Robinson Astbury 2007

New routes to structure?

- Cryo-EM
 - real-space image, but not dose-efficient
- Inversion of diffraction
 - dose-efficient, especially for phase contrast
 - about equally efficient for photons or electrons
- How to beat the dose limit?

Do it faster!

Dose-resolution Relationship For 3D Imaging Of Frozen-hydrated Samples

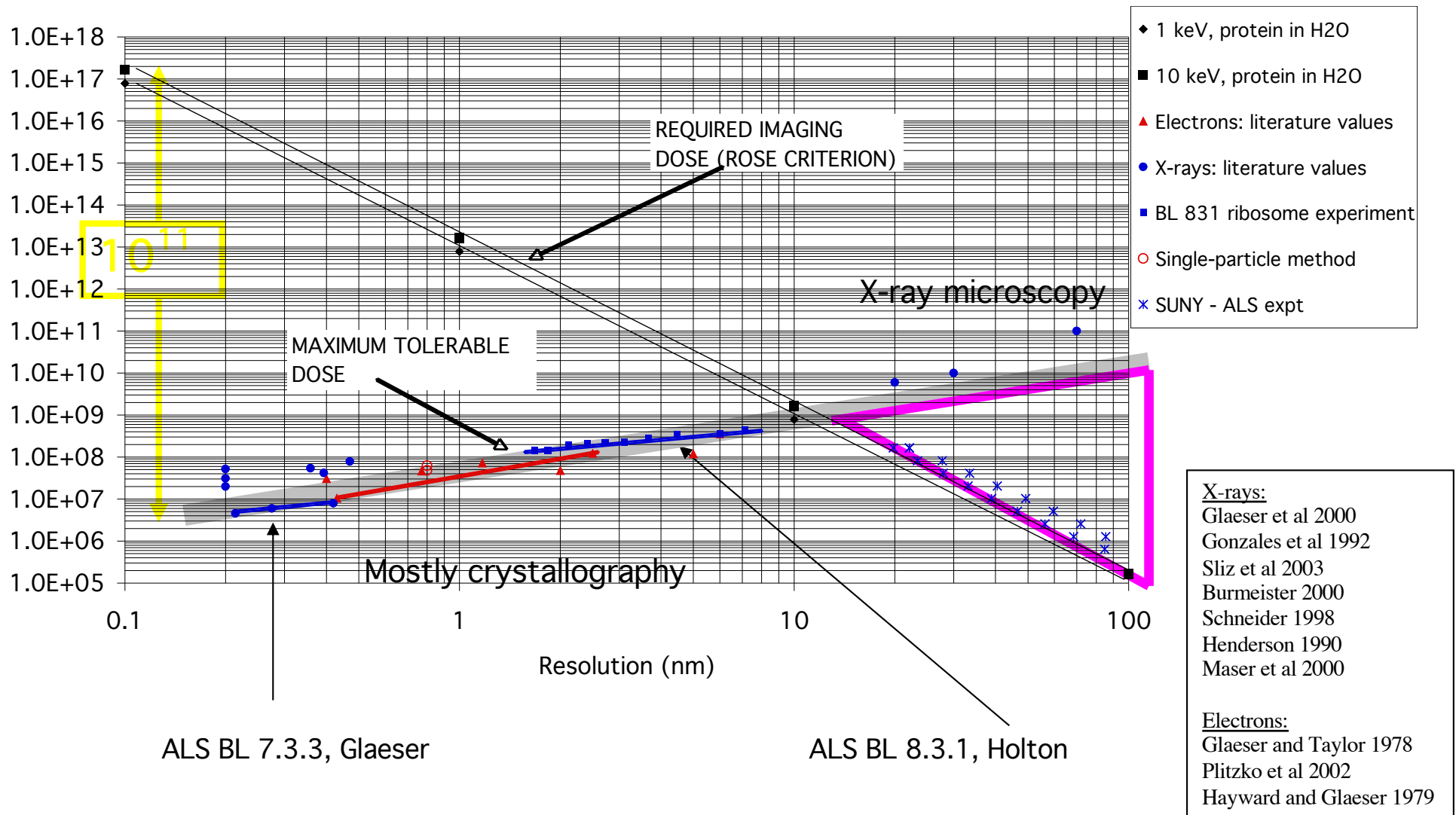

c/o Malcolm Howells, ALS

Astbury 2007

How fast must we go?

- Radiation breaks bonds and ionizes matter
- Inertial response of nucleus to broken bond
- Structure is 'lost' when an atom moves by one bond-length
- Phonon vibration time: 10^{14} Hz = 10fs
- Photons better than electrons (space charge)
- Possible with X-ray free-electron laser (XFEL)

Conclusions

- Smallest Ferritin crystals about 3 microns
- Implosion due to radiation damage
- Expanded aggregate state upon freezing
- Model SAXS using clusters
- Single molecule diffraction ideas can be tested using nanocrystals
- Phase objects 'equally' accessible
- Come to Diamond!