

FAST TRACK COMMUNICATION

Nondiscriminatory propagation on trees

Simone SeveriniInstitute for Quantum Computing and Department of Combinatorics & Optimization,
University of Waterloo, Waterloo N2 L 3G1, Canada

Received 2 June 2008, in final form 10 August 2008

Published 22 October 2008

Online at stacks.iop.org/JPhysA/41/482002**Abstract**

We consider a discrete-time dynamical process on graphs, firstly introduced in connection with a protocol for controlling large networks of spin 1/2 quantum mechanical particles [Burgarth and Giovannetti 2007 *Phys. Rev. Lett.* **99**, 100501]. A description is as follows: each vertex of an initially selected set has a packet of information (the same for every element of the set), which will be distributed among vertices of the graph; a vertex v can pass its packet to an adjacent vertex w only if w is its only neighbor without the information. By means of examples, we describe some general properties, mainly concerning homeomorphism and redundant edges. We prove that the cardinality of the smallest sets propagating the information in all vertices of a balanced m -ary tree of depth k is exactly $(m^{k+1} + (-1)^k)/(m + 1)$. For binary trees, this number is related to alternating sign matrices.

PACS number: 03.67.-a

1. Introduction

Background. In view of applications such as quantum RAM or charge-coupled devices, Burgarth and Giovannetti [2] introduced a protocol for arbitrarily control networks of coupled spin 1/2 quantum particles (for example, an array of trapped ions). An important feature of the protocol lies on the ability of transforming the physical state of the entire network, by acting sequentially with the same local operation on a specific subset of particles. This is valuable, since physical operations on quantum objects are generally difficult to implement. It has been shown in [2] that a network can be prepared in an arbitrary state by acting on the particles of a subset, only if that subset satisfies certain conditions related to the eigensystem of the Hamiltonian. Such conditions can be lifted from the physical scenario and analyzed in a purely combinatorial setting. This can be described in what follows as a discrete-time dynamical process on graphs.

Definition. A (simple) graph $G = (V, E)$ is an ordered pair of sets defined as follows: $V(G)$ is a non-empty set, whose elements are called *vertices*; $E(G)$ is a non-empty set of unordered

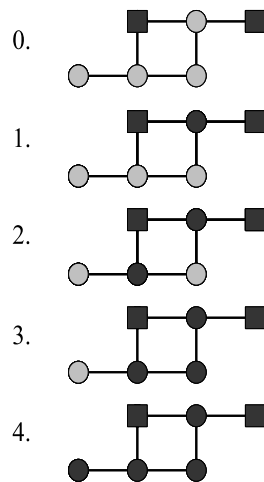

Figure 1. The illustration of the steps of the propagation process taking place on a small graph G , as an example. The square vertices are the elements included in $\mathcal{P}_S(0)$ at the beginning of the process. The other black vertices are the elements of the set $\mathcal{P}_S(t) \setminus \mathcal{P}_S(0)$, with $t = 1, 2, 3, 4$. The grey vertices are the elements of $V(G) \setminus \mathcal{P}_S(t)$. The steps are then represented by five diagrams with time flowing from the top diagram (the diagram labeled by 0) to the bottom one (the diagram labeled by 4.). For this specific graph $\mathcal{P}_S(4) = V(G)$. Therefore, the propagation is able to cover the vertex set entirely.

pairs of vertices, whose elements are called *edges*. Let $G = (V, E)$ be a graph with $V(G) = \{1, 2, \dots, n\}$. Given a set $S \subseteq V(G)$, let $N[S] = \{w \in V(G) \setminus S : \exists v \in S : \{v, w\} \in E(G)\}$ be the (closed) neighborhood of S . Let $\mathcal{P}_S : [n] \rightarrow V(G)$ be a map associating a subset of $V(G)$ to each *time* $t \in [n] = \{0, 1, \dots, n - 1\}$. We consider the following process:

- We select a set $S \subseteq V(G)$ and fix $\mathcal{P}_S(0) = S$.
- For each $t \in [n] \setminus \{0\}$, we have $\mathcal{P}_S(t) = \mathcal{P}_S(t - 1) \cup T$, where $T \subseteq N[\mathcal{P}_S(t - 1)]$. Moreover, if $w \in \mathcal{P}_S(t) \setminus \mathcal{P}_S(t - 1)$ then there is $v \in \mathcal{P}_S(t - 1)$ such that $\{v, w\} \in E(G)$ and $N[v] \setminus \{w\} \subseteq \mathcal{P}_S(t - 1)$.

In other words, at time $t = 0$, we select a subset of vertices $\mathcal{P}_S(0)$. At time $t = 1$, we may insert some vertices into $\mathcal{P}_S(0)$ and obtain $\mathcal{P}_S(1)$. The *propagation* will go on until eventually $\mathcal{P}_S(k) = V(G)$, for some k . Clearly, $k \leq n - 1$. However, the propagation is not free, but it obeys some rules. Specifically, a vertex w can be inserted at time t in $\mathcal{P}_S(t)$, only if it is adjacent to $v \in \mathcal{P}_S(t - 1)$ and all other neighbors of v (except w itself) are already in $\mathcal{P}_S(t - 1)$. If there is k such that $\mathcal{P}_S(k) = V(G)$, we say that S *propagates* to G . We denote this fact by $S \curvearrowright G$. Note that $\mathcal{P}_S(t - 1) \subseteq \mathcal{P}_S(t)$. We denote by $\#A$ the cardinality of a generic set A . It is important to remark that not every set $\mathcal{P}_S(0)$ is able to propagate to the entire graph. In fact, there are cases in which the propagation stalls. This can happen if $\mathcal{P}_S(0)$ does not contain a sufficiently large number of vertices. Additionally, the propagation process may still halt before it has extended to the entire graph, because of a wrong choice of initial vertices even if their number is large enough. Figure 1 represents the steps of the described dynamical process taking place on a small graph. We shall adopt the convention that in all figures time goes from top to bottom.

Interpretation. We may depict the above scenario in a more concrete language: each vertex of an initially selected set has a packet of information (the same for every vertex in the set), which has to be diffused among the vertices of the graph; a vertex v can pass its packet to an adjacent

vertex w only if w is its only neighbor still without the information. In this way, v does not need to *discriminate* among its neighbors, even if it is permitted to pass the information to only one of those. Equivalently, this can be interpreted as a procedure for coloring (with the same color) the vertices of a graph, in such a way that a vertex can be colored at a certain time step, only if it is the unique uncolored neighbor of an already colored vertex. Note that the propagation is not *synchronized*, that is, we do not require that at a certain time k , a vertex is necessarily included in $\mathcal{P}_S(k)$ if it is the unique uncolored neighbor of a colored vertex.

A quantitative question. Here is a precise mathematical problem: given a simple undirected graph G , find a set of minimum cardinality that does propagate in G . The cardinality of such a set will be denoted by $\pi(G)$. Obviously $\pi(G)$ is invariant under isomorphism, since it does not depend on the labeling of the vertices. Note that in this problem we do not take into consideration the *propagation time*. The problem can be in fact modified by imposing time constraints. Finding $\pi(G)$ is of practical importance, when trying to optimize the number of local operations required to initialize and then control, a networks of spin 1/2 particles. The computational complexity aspects of the question, a formulation as an orientation problem, and approximation algorithms are studied in [1]. Roughly speaking, it looks like that $\pi(G)$ depends on the expansion properties of G . Intuitively higher is the number of ‘ways out’ from each subset of vertices of a certain size and higher is $\pi(G)$.

Summary of results and structure of the paper. We shall focus mainly on trees. Apart from the introduction, this paper contains two sections. In section 2, we underline some general properties of propagation, by taking as examples paths, combs and stars. We focus on homeomorphism and the maximum possible number of edges that a graph can have, given the cardinality of the initial set $\mathcal{P}_S(0)$. We finally make a comment about Hamiltonicity and propagation in digraphs. In section 3, we will focus on balanced trees. As a main observation, we prove that the cardinality of the smallest set propagating in all vertices of a balanced m -ary tree of depth k is exactly $(m^{k+1} + (-1)^k)/(m + 1)$. For balanced binary trees these integers realize the Jacobsthal sequence, which is related to alternating sign matrices. The last section is a brief conclusion.

Our reference on the theory of graphs for the terminology not defined here is the book by Diestel [5].

2. General facts by example

Homeomorphism. It is worth keeping in mind that $\pi(G)$ is invariant under homeomorphism. It is then more appropriate to think about $\pi(G)$ not as a quantity associated with a single graph G , but rather to a family of graphs, whose members are all the graphs homeomorphic to G . Recall that graphs G and H are *homeomorphic* if $H(G)$ can be obtained by subdivision and smoothing on G (H): a *subdivision* of an edge $\{u, v\}$ consists of deleting $\{u, v\}$, adding a vertex w , plus the edges $\{u, w\}$ and $\{w, v\}$; a *smoothing* is the reverse operation, and it is then performed only on vertices of degree two. A *tree* is a graph in which any two vertices are connected by exactly one path. This property, plus the homeomorphism remark, makes propagation on trees particularly amenable to quick observations.

Paths. Let P_n be the path of length n . The path P_n models the classic spin chain with equal nearest neighbor couplings or more complex networks via the notion of graph covering and equitable partitions (see, e.g., [3]). This is probably the graph for which $\pi(G)$ is simplest to determine. Indeed $\pi(P_n) = 1$, for every n . This fact is self-evident and it does not need a proof. If $V(P_n) = \{1, 2, \dots, n\}$ and $\{v, w\} \in E(G)$ only if $w = v + 1$, then it is sufficient

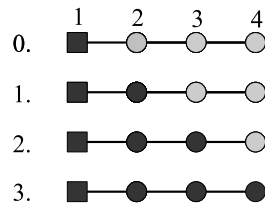

Figure 2. Propagation on the path P_4 : here $\mathcal{P}_S(0) = \{1\}$. For a path on n vertices, $\mathcal{P}_S(n-1) = V(P_n)$. In fact, $\mathcal{P}_S(3) = \{1, 2, 3, 4\}$, as we can see in the bottom diagram.

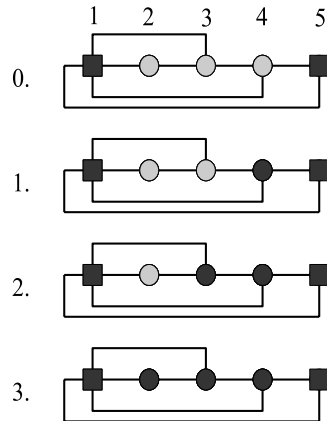

Figure 3. Propagation on the graph $C_5 + \{2, 5\} \cup \{3, 5\}$: here $\mathcal{P}_S(0) = \{1, 5\}$ and $\mathcal{P}_S(3) = \{1, 2, 3, 4, 5\}$, as we can see in the bottom diagram. This graph is useful to point out that augmenting C_n with extra edges can still keep $\#S = 2$. In general, it is nontrivial to determine if we can add edges to a given graph by keeping fixed the cardinality of S .

to take $S = \{1\}$ or $S = \{n\}$. Clearly, $\mathcal{P}_S(n-1) = V(P_n)$. Let $G_n = (V, E)$ be a graph in which $\#V(G) = n$. Let $\mathcal{G} = \{G_n : G_n \text{ satisfies a property } P \text{ for all } n\}$ be a family of graphs. We can look at the number $\pi(G_n)$ as a function $f : \mathbb{Z} \rightarrow \mathbb{Z}$, defined as $f(n) = \pi(G_n)$, for all $G_n \in \mathcal{G}$. We have seen that $\pi(P_n) = 1$ is independent of n . This suggests the following structural graph theory problem: characterize classes of graphs \mathcal{G} , for which $\pi(G_n) = c$, where c is a constant, for all $G_n \in \mathcal{G}$. Paths have this behavior, since $\pi(P_n) = 1$, for all n . The same can be said for n -cycles, since $\pi(C_n) = 2$. For complete graphs this is a linear function: $\pi(K_n) = n - 1$. Figure 2 describes how $\{1\} \curvearrowright P_4$.

Adding edges (I). Since $\pi(P_n) = 1$ and the minimum degree of P_n is 1, it is also natural to ask about graphs for which $\pi(G)$ is exactly the minimum degree, that is, the trivial lower bound. Paths also suggest another question: given a graph G on n vertices and $S \subset V(G)$, what is the maximum number of edges that G can have such that $S \curvearrowright G$. One can obtain a cycle C_n from a path P_n by adding an extra edge to P_n . For covering C_n by propagation, we need $\#S \geq 2$. Specifically, if S contains just two adjacent vertices then $S \curvearrowright C_n$. Can we augment C_n by extra edges and keep $\#S = 2$? Let $E(C_n) = \{1, 2\}, \{1, n\}, \{2, 3\}, \dots, \{n-1, n\}$. Let $S = \{1, n\}$. Still $S \curvearrowright C_n + \{2, n\}$. More generally, $S \curvearrowright C_n + \bigcup_i \{2, i\}$. It is plausible to conjecture that when $\#S = 2$ and $V(G) = n$, then $\#E(G) = 2n - 3$ ($n \geq 2$) is the maximum possible number of edges that G can have if $S \curvearrowright G$. The graph $C_n + \bigcup_i \{2, i\}$ attains the bound. Figure 3 describes how $\{1, 5\} \curvearrowright C_5 + \{2, 5\} \cup \{3, 5\}$.

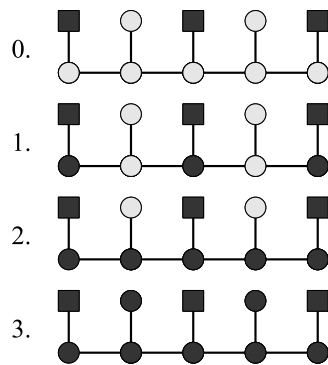

Figure 4. Propagation in $P_{5,2}$.

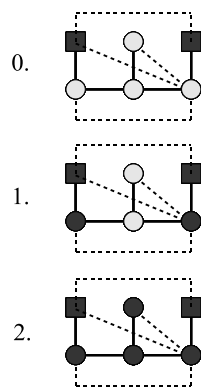

Figure 5. Propagation on the comb $P_{3,2}$ saturated with an additional number of edges. The extra edges are represented by dotted lines. Note that adding a single vertex to a graph, in which we have already fixed the initially selected vertices, may be sufficient to stop the propagation.

Combs. A comb $P_{n,k}$ is a path P_n having a copy of P_k attached to each vertex. Usually the plane embedding of this tree is such that the copies of P_k are all drawn in the upper region of the plane determined by P_n . This justifies the term ‘comb’; the path P_n is then called *bone* and the paths P_k are called *fingers*. So, $\#V(P_{n,k}) = kn$. The comb $P_{n,k}$ has two vertices of degree 2, $n - 2$ vertices of degree 3, and $kn - n + 2$ vertices and k vertices of degree 1. Given the invariance under homeomorphism, it is sufficient to deal with $P_{n,2}$. In fact, longer fingers attached to the vertices of the bone P_n would not modify $\pi(P_{n,k})$. Equivalently, $\pi(P_{n,k}) = \pi(P_{n,2})$ for every k . We have $\pi(P_{n,2}) = n/2$ if n is even and $\pi(P_{n,2}) = \lceil n/2 \rceil$ if n is odd. Figure 4 shows how a three-element set propagates in $P_{5,2}$.

Adding edges (II). As we have already seen in the previous paragraphs, in some situations one can add edges, and a pre-selected set will still propagate in the graph. Certainly, one can always add edges connecting only the pre-selected vertices and create a clique of size $\#S$. In combs, different from the case of C_n , we can construct a clique of size $n/2$, containing then $\frac{1}{8}n^2 - \frac{1}{4}$ edges. This implies that the total number of edges is going to increase with a faster pace than in C_n augmented by *redundant* edges (see figure 5). In a generic graph, we can always add redundant edges connecting vertices in S and then complete the subgraph induced

by S to a clique, without altering the dynamics. Other edges can be added provided that these satisfy some conditions. Given $v \in \mathcal{P}_S(t)$, if we can add $\{v, w\} \in E(G)$ then

- (i) Suppose $w \in \mathcal{P}_S(t)$. Then there is a vertex y such that $y \curvearrowright w$ at time $r < t$.
- (ii) Suppose $w \notin \mathcal{P}_S(t)$.
 - (a) If $N[v] \subseteq \mathcal{P}_S(t)$ then we can simply proceed to include w in $\mathcal{P}_S(t+1)$.
 - (b) If $N[v] \not\subseteq \mathcal{P}_S(t)$ then there is a vertex y such that $y \curvearrowright w$ at a time $t' < t''$, where t'' is the time step at which $v \curvearrowright z$, for some vertex z .

We ask: what is the maximum number of edges in $P_{n,2}+H$ so that $\pi(P_{n,2}) = \pi(P_{n,2}+H)$? What about graphs in general? The answer is not immediate and we leave it as an open problem.

Stars. The complete bipartite graph $K_{1,n-1}$ is also said to be a *star* on n vertices. Contextually to quantum networks, properties of free bosons hopping on star networks were investigated in [6]. If $S \curvearrowright K_{1,n-1}$ then $\#S = n - 2$, by taking $n - 2$ leaves (i.e., the vertices of degree 1). Among all graphs on n vertices, the complete graph K_n is the only graph for which the ratio $n/\#\mathcal{P}_S(0)$ is smaller. If we include the root in S (i.e., the vertex of degree $n - 1$), then $\#S = n - 1$. This implies that we can add $\frac{1}{2}n^2 - \frac{3}{2}n + 1$ redundant edges to $K_{1,n-1}$ and obtain K_n such that $S \curvearrowright K_{1,n-1}$ and $S \curvearrowright K_n$, for exactly the same set S . If a graph G has $K_{1,n-1}$ as a spanning subgraph then $\#\mathcal{P}_S(0) \in \{n - 2, n - 1\}$, for G . Recall that a *spanning subgraph* is a subgraph that contains all the vertices of the original graph. Valuable remarking that if a set propagates in a graph then it will propagate in all of its spanning subgraphs. Equally, the minimum cardinality of such a set is nonincreasing when restricting ourselves to spanning subgraphs.

Digraphs and Hamiltonicity. An *orientation* of a graph G is a directed graph \vec{G} obtained by giving a direction to the edges of G and in this way substituting $E(G)$ with a set of directed *arcs*. The propagation dynamics induces a partial ordering on the vertices of G and therefore an orientation. Observe that the definition given in the introduction of this communication can be extended to digraphs in a straightforward way. We ask: given a graph G , can we always find an orientation \vec{G} and a set S such that $S \curvearrowright \vec{G}$ and $\#S = 1$? If G has a Hamilton path then the answer is in the affirmative, because we can just orient *forward* the edges of the Hamilton path and *backwards* the remaining edges. Note that the grid considered in [2] is Hamiltonian. We can then always take a single vertex to propagate in an arbitrary large grid, as far as we give a proper orientation to the edges. Formally, let \vec{P}_n be the Hamilton-directed path and let $S = \{1\}$. With respect to \vec{G} , we have $\mathcal{P}_S(t) = \{1, 2, \dots, t\}$, for each t . The arc set of \vec{G} is $E(\vec{G}) = E(\vec{P}_n) \cup \{(u, v) : \{u, v\} \in E(G) \wedge v < u\}$. In the oriented version, we get $\#\mathcal{P}_S(0) = 1$ also for the complete graph. For K_n , the orientation giving rise to a Hamilton-directed path is obtained by constructing any Hamiltonian tournament. An example is given in figure 6.

3. Balanced trees

Let us denote by $T_{2,k}$ a *balanced binary tree of depth k* . Then $\#V(T_{2,k}) = 2^k - 1$. The root of $T_{2,k}$ is denoted by v . All the remaining vertices are denoted by v_x , where $x \in \{0, 1\}^i$, for $i = 1, \dots, k - 1$. In particular, $\{v, v_0\}, \{v, v_1\} \in E(T_{2,k})$ and $\{v_x, v_{x0}\}, \{v_x, v_{x1}\} \in E(T_{2,k})$, for every $x \in \{0, 1\}^i$ and $i = 1, \dots, k - 2$. The number of time steps needed to cover a tree is necessarily equal to the diameter of the tree.

Top-down propagation. A set S is said to propagate in $T_{2,k}$ by *top-down* propagation, when it propagates in $T_{2,k}$ and if $v_x \in \mathcal{P}_S(t)$ then $x \in \{0, 1\}^i$, with $i \leq t + 1$, for every t . Equivalently, in

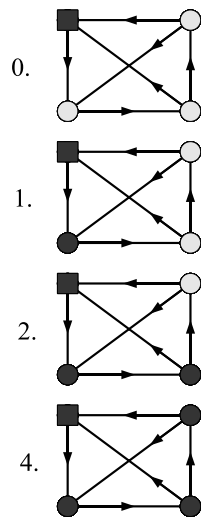

Figure 6. A single vertex propagating in an orientation of the graph K_4 . A single vertex is sufficient to propagate on a Hamiltonian graph once an orientation has been chosen.

top-down propagation, the *information flow* goes from the root to the leaves. As a consequence, $v \in \mathcal{P}_S(0)$. It is straightforward to determine $\pi_{TD}(T_{2,k})$, i.e., the cardinality of the smallest set covering $T_{2,k}$ by top-down propagation: given a tree $T_{2,k}$, we have $\pi_{TD}(T_{2,k}) = 2^{k-1}$. Let us see why. If $S = \{v\}$ then $\mathcal{P}_S(1) = S$. So, we need to include v_0 or v_1 in S . Let us take $S = \{v, v_0\}$. Now, $\mathcal{P}_S(1) = \{v, v_0, v_1\}$. However, $\mathcal{P}_S(2) = \mathcal{P}_S(1)$. So, we need to include v_{00}, v_{01}, v_{10} or v_{11} in S . In this way, if $S = \{v, v_0\} \cup \{v_x : x = y0 \wedge y \in \{0, 1\}^i, 1 \leq i \leq k-2\}$ then $S \curvearrowright G$. It is then clear that $\pi_{TD}(T_{2,k}) = \#S = 2^{k-1}$.

Bottom-up propagation. A set S is said to propagate in $T_{2,k}$ by *bottom-up* propagation, when it propagates in $T_{2,k}$ and if $v_x \in \mathcal{P}_S(t)$ then $x \in \{0, 1\}^i$, with $i = k - 1$ if $t = 0$, $i = k - 2$ if $t = 1$, and so on. Equivalently, in bottom-up propagation, the information flow goes from the leaves (i.e., the vertices of the form v_x , with $x \in \{0, 1\}^{k-1}$) to the root. It is obvious that $T_{2,k}$ is covered by bottom-up propagation if $\mathcal{P}_S(0)$ is the set of all leaves, that is $\#\mathcal{P}_S(0) = 2^{k-1}$. This is not equal to the optimum, if we want that $v \in S$ only if v is a leaf, without any further constraint. Figure 7 describes bottom-up propagation in $T_{2,3}$. We will give a formal proof of the next result, a technical lemma for establishing theorem 2.

Lemma 1. For $T_{2,k}$ be a balanced binary tree of depth k . Then $\pi_{leaf}(T_{2,k}) = \pi(T_{2,k}) = \frac{2^k + (-1)^{k-1}}{3}$, i.e., the $(k - 1)$ th Jacobsthal number.

Proof. First, take $T_{2,3}$. It is useful to write $\mathcal{P}_S^k(0)$ and S^k when considering $T_{2,k}$. Suppose the elements of $\mathcal{P}_S^3(0)$ being leaves only. We can start by including in S^3 a single vertex, say v_{00} , in agreement with the notation defined. We will think of the information flow going from *bottom-left* to *bottom-right*, with the propagation starts from v_{00} and ending at v_{11} . (Just think of $T_{2,3}$ drawn on the plane in the usual way.) We will add vertices in S *online*, as required, every time the propagation stops. In this way, we provide that $\#S$ is as small as possible. We have $v_{00} \overset{1}{\curvearrowright} v_0$ only if $v_{01} \in \mathcal{P}_S^3(0)$. The notation is easy: v_{00} propagates to v_0 at time 1. Now $S^3 = \{v_{00}, v_{01}\}$. So, $v_0 \overset{2}{\curvearrowright} v$ and $v \overset{3}{\curvearrowright} v_1$. At this stage, $v_1 \overset{4}{\curvearrowright} v_{11}$ only if $v_{10} \in S^3$. At the

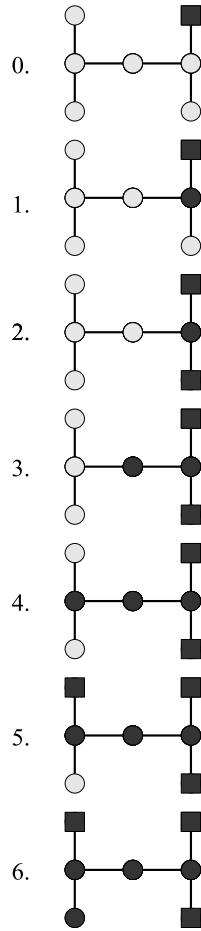

Figure 7. Bottom-up propagation in the graph $T_{2,3}$. Information tends to propagate from the leaves to the root.

end, $S^3 = \{v_{00}, v_{01}, v_{10}\}$ and $\#S^3 = 3$. It follows that $\pi_{\text{leaf}}(T_{2,3}) = \pi(T_{2,3}) = 3$. The tree $T_{2,4}$ can be constructed by taking two copies of $T_{2,3}$ and adding an extra vertex adjacent of the roots of the smaller trees. The new vertex is the root of $T_{2,4}$. We can include the set S^3 in $\mathcal{P}_S^4(0)$ for $T_{2,4}$. The root of $T_{2,4}$ is automatically covered and so the vertex $v_1 \in V(T_{2,4})$. This is sufficient to show that the set $S^4 = \{v_{000}, v_{001}, v_{100}, v_{110}\}$ propagates in $T_{2,4}$. So, $\#\mathcal{P}_S^4(0) = (2 \cdot \#\mathcal{P}_S^3(0)) - 1 = 5$. Let G be the graph obtained by adding a pendant vertex to the root of $T_{2,4}$ (i.e., a vertex of degree one). For this graph $\pi(G) = \#\mathcal{P}_S^4(0) + 1 = 6$ puts in evidence a recursive way to obtain $\pi_{\text{leaf}}(T_{2,k})$. Since $T_{2,k+1}$ is constructed with two copies of $T_{2,k}$ plus a new root, we can write $\#\mathcal{P}_S^k(0) = 2(\#\mathcal{P}_S^{k-1}(0)) + 1$, for k odd, and $\#\mathcal{P}_S^k(0) = 2(\#\mathcal{P}_S^{k-1}(0)) - 1$, for k even. Such quantities are exactly $\pi_{\text{leaf}}(T_{2,k}) = \pi(T_{2,k})$ because the vertices inserted online in S^k are leaves. Odd and even cases are combined in the formula $\pi(T_{2,k}) = \frac{2^k + (-1)^{k-1}}{3}$, the $(k - 1)$ th Jacobsthal number [9]. \square

It has been pointed out that a set $S \curvearrowright G$ if S represents a configuration incompatible with a nontrivial eigenstate of the network Hamiltonian [2]. Connections between the ground-

state vector for some special spin systems and the alternating-sign matrices (ASMs) form an active field of research in the interface between combinatorics, statistical mechanics and condensed matter (see [7] and the references therein). The number of ASMs of size n is $A(n) = \prod_{l=0}^{n-1} \frac{(3l+1)!}{(n+l)!}$. Frey and Sellers [4] proved that $A(n)$ is odd if and only if n is a Jacobsthal number. This observation could reveal a potential link between ASMs and the physics (e.g., properties of the eigensystem) involved in the protocol proposed in [2], for networks modeled by trees.

Theorem 2 is the main point of this section. The proof is essentially the same as that of lemma 1. The sequences realized by $\pi(T_{m,k})$ can be seen as generalizations of the Jacobsthal numbers.

Theorem 1. *Let $T_{m,k}$ be an balanced m -ary tree of depth k . Then $\pi_{\text{leaf}}(T_{m,k}) = \pi(T_{m,k}) = \frac{m^{k+1} + (-1)^k}{m+1}$.*

The table below contains the first values of $\pi(T_{m,k})$:

m/k	1	2	3	4	5	6
1	1	0	1	0	1	0
2	1	1	3	5	11	21
3	1	2	7	20	61	182
4	1	3	13	51	205	819
5	1	4	21	104	521	2604
6	1	5	31	185	1111	6665

The number $Q_{m,k} = \sum_{i=0}^{k+1} (-1)^{k+1-i} m^{k+1-i}$ is the mk th entry of the table, disregarding of the signs. All sequences realized by the rows of the table appear to count walks of length k between any two vertices in the complete graph K_{m+1} , i.e., these are equal to $A(K_{m+1})_{i,j}^k$ (with $i \neq j$), where $A(K_m)$ is the adjacency matrix of K_m . It is an open problem to exhibit a bijection between each element in an initially selected set of minimal cardinality propagating in $T_{m,k}$ and walks of length k in K_{m+1} .

4. Conclusion

We have considered the dynamical process on graphs introduced in [2]. The process can be described as a discrete propagation of information on graphs obeying certain rules. By means of examples, we described some general properties. Focusing on trees, we proved that the cardinality of the smallest set propagating the information in all vertices of a balanced m -ary tree of depth k is exactly $(m^{k+1} + (-1)^k)/(m + 1)$. For binary trees, this number is related to alternating sign matrices. Given that the propagation model arises from a protocol for controlling networks of coupled spin 1/2 quantum particles, a deeper analysis of this last observation may enrich the already strong correspondence (see, e.g., [8]) between ground states of certain spin systems and alternating sign matrices.

Acknowledgments

The propagation model described here has been suggested to me by Vittorio Giovannetti, during the ‘The first International Iran Conference on Quantum Information (IICQI)’, held at Kish Island, in September 2007. I would like to thank Ashkan Aazami and Joseph Cheriyan for their interest and encouragement. I acknowledge the financial support of DTO-ARO,

ORDCF, Ontario-MRI, CFI, CIFAR and MITACS. Thanks to the anonymous referees for their comments and suggestions.

References

- [1] Aazami A Approximation algorithms and hardness for the propagation problem Unpublished
- [2] Burgarth D and Giovannetti V 2007 Full control by locally induced relaxation *Phys. Rev. Lett.* **99** 100501 (arXiv:0704.3027v1)
- [3] Bose S 2007 Quantum communication through spin chain dynamics: an introductory overview *Contemp. Phys.* **48** 13–30 (arXiv:0802.1224v1)
- [4] Frey D D and Sellers J A 2000 Jacobsthal numbers and alternating sign matrices *J. Integer Seq.* **3** 1–15
- [5] Diestel R 2000 Graph theory *Graduate Texts in Mathematics* 2nd edn (New York: Springer) <http://www.math.uni-hamburg.de/home/diestel/books/graph.theory>
- [6] Mancini F P, Sodano P and Trombettoni A 2007 BEC in a star-comb graph *Lectures on the Physics of Strongly Correlated Systems XI AIP Conference Proc.* (vol 918) ed A Avella and F Mancini (New York: AIP Press) pp 302–307 (arXiv:cond-mat/0612388v1)
- [7] Propp J 2001 The many faces of alternating-sign matrices. Discrete models: combinatorics, computation, and geometry *Discrete Math. Theor. Comput. Sci. Proc., AA, Maison Inform. Math. Discrèt. (MIMD), (Paris, 2001)* 43–58 (arXiv:math/0208125v1)
- [8] Razumov A V and Stroganov Yu G 2006 Bethe roots and refined enumeration of alternating-sign matrices *J. Stat. Mech.* **P07004** (arXiv:math-ph/0605004v2)
- [9] Sloane N J A 2008 The on-line encyclopedia of integer sequences at <http://www.research.att.com/njas/sequences/>